



*Service, Solutions, Performance*



# METRIC SEALS

Salt Lake City + Utah + USA  
001-801-973-9171 Fax 001-801-973-9188  
© Macrotech Polyseal Inc. May 2003









Rev# MSC-1000

# Table of Contents

## Macrotech Polyseal

About MPI	.....	2
MPI Products	.....	3
Product Selection	.....	4







## Rod Seals

UBR Seal		UNR Seal		.....	8		
Type B Polyseal							
Deep Z Seal		DZR Seal		.....	8		
Buffer Seals®	R 	RB		RS		.....	9
Spectraseals®				.....	10-12		

## Rod Wipers

MC Wiper		SH Wiper		.....	13		
DT Wiper		D Wiper		H Wiper		.....	14

## Piston Seals

PTFE Piston Ring		.....	15
PTFE Square Ring Energized Piston Ring		.....	16
Crown Seal®		.....	17
Piston U-Cup		.....	18
Grooved Piston Ring		.....	19
Capped T Piston Seal®		.....	20
Fluids	.....	21	

## Wear Guides

WGT		.....	22-23
-----	---	-------	-------

# ABOUT MPI

Macrotech Polyseal, Inc. started in 1973 and is now a privately held business where employee safety, quality products, superior customer service and teamwork are top priorities. Macrotech Polyseal Inc. (MPI) is a premier producer of hydraulic and pneumatic seals, excluders and wear guides. Based in Salt Lake City, Utah MPI utilizes over 15,000 square meters of floor space in its operations. Through over fifty distributors worldwide, MPI offers solutions to nearly all fluid sealing requirements.

MPI has experienced success due to its continuous commitment to quality and innovation. Dedication to producing the best product for the application has brought MPI significant attention and market share in the fluid power industry. Sealing solutions is a "way-of-business" at MPI.

**M.P.I is an ISO 9001 registered manufacturer.**

## Engineering Support

MPI is a customer-driven company with engineers dedicated to serving customers' needs. MPI engineers deal with distributors, cylinder manufacturers and end-users to develop solutions to difficult sealing problems. The Engineering Department welcomes questions from customers in order to better serve your needs.

MPI directs the sales of its products through trained, Authorized Distributors. By developing and maintaining a close relationship between the Engineering Department, sales correspondence, distributors and end-users - MPI provides the finest fluid power products to its customers worldwide.

MPI offers the three primary seal manufacturing techniques in one location. Compression molding for thermoset elastomers such as nitrile, fluorocarbon and ethylene propylene rubbers. Injection molding for thermoplastic materials such as urethane, polyester and nylon parts. Finally, machined engineered plastics to serve the filled-PTFE market and extreme conditions and environments. By producing in these three methods, MPI offers over 70 distinct products in thousands of different sizes. Our goal is to offer our customers solutions. By controlling all processes; from molds to tooling, design to production, MPI offers all our customers the right products for the job.

A joint venture, Marotech Focker, Ltda. of Brazil, has already become a leader in materials and seal design throughout South America.

## Production

MPI produces netmolded products rather than trimming seal lips, as is typical in the industry. By eliminating the trimming process, MPI manufactures consistent parts for our customers without deviations caused by the trimming equipment and process. Parts from 2mm to 1000mm, depending upon the material selected, can be produced by injected molding. Whereas, rubber parts to 500mm and PTFE machined items range from 2mm to 500mm. All finished products must adhere to final quality control inspection and audit.



# ROD SEALS

## UBR - Seal

	HEAVY DUTY MOBILE HYDRAULIC	HIGH DUTY CYCLE Pressure: 400 bar Temperature: -40°C - +120°C Velocity: 1,0 m/s max Surface Finish: Ra 0,1-0,4 μm	U-1023 HP LUBRITHANE® U-1028 EXHP LUBRITHANE U-1027 EXHP LUBRITHANE
---	--------------------------------	---	---

## Unsymmetrical U-CUP

	MOBILE HYDRAULIC AGRICULTURAL GENERAL INDUSTRIAL	MEDIUM DUTY CYCLE Pressure: 400 bar Temperature: -40°C - +120°C Velocity: 1,0 m/s max Surface Finish: Ra 0,1-0,4 μm	U-1023 HP LUBRITHANE U-1028 EXHP LUBRITHANE U-1027 EXHP LUBRITHANE
---	--	---	--

## Type B Polyseal

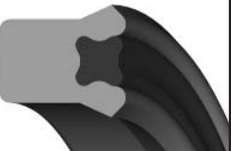
	MOBILE HYDRAULIC AGRICULTURAL GENERAL INDUSTRIAL	HIGH DUTY CYCLE Pressure: 400 bar Temperature: -40°C - +120°C Velocity: 1,0 m/s max Surface Finish: Ra 0,1-0,4 μm	U-1003 LUBRITHANE (100°C) U-1023 HP LUBRITHANE U-1028 EXHP LUBRITHANE
---	--	---	---

## Deep Z-Seal

	HEAVY DUTY MOBILE HYDRAULIC TELESCOPIC CYLINDER	HIGH DUTY CYCLE Pressure: 400 bar Temperature: -54°C - +105°C Velocity: 1,0 m/s max Surface Finish: Ra 0,1-0,4 μm	A-8504 LOW-TEMP. NITRILE LIP U-1003 LUBRITHANE BASE
---	---	---	--

## Deep Z-Seal with Delta Anti-Extrusion Ring

	HEAVY DUTY MOBILE HYDRAULIC HIGH PRESSURE	HIGH DUTY CYCLE Pressure: 500 bar Temperature: -54°C - +105°C Velocity: 1,0 m/s max Surface Finish: Ra 0,1-0,4 μm	A-8504 LOW-TEMP NITRILE LIP U-1003 LUBRITHANE BASE (100°C) P-2506 NYLON ANTI-EXTRUSION
--	---	---	--

## R Style Buffer Seal

	LOW FRICTION HEAVY DUTY MOBILE HYDRAULIC	HIGH DUTY CYCLE Pressure: 700 bar Temperature: -54°C - +200°C Velocity: 1,0 m/s max Surface Finish: Ra 0,1-0,4 μm	741 40% BRONZE PTFE A-8501 NITRILE Customer supplied O-Ring Required.
---	--	---	---

## RB Style Buffer Seal

	HEAVY DUTY MOBILE HYDRAULIC HIGH PRESSURE	HIGH DUTY CYCLE Pressure : 700 bar Temperature: -54°C - +120°C Velocity: 1,0 m/s max Surface Finish: Ra 0,1-0,4 μm	U-1023 HP LUBRITHANE® NYLON ANIT-EXTRUSION U-1027 EXHP LUBRITHANE
---	---	--	---

## RS Style Buffer Seal

	HEAVY DUTY MOBILE HYDRAULIC	HIGH DUTY CYCLE Pressure: 700 bar Temperature: -54°C - +200°C Velocity: 1,0 m/s max Surface Finish: Ra 0,1-0,4 μm	741 40% BRONZE PTFE A8501 Nitrile
---	--------------------------------	---	--------------------------------------

## Spectraseal®

	PETRO-CHEMICAL LOW FRICTION EXTREME TEMPERATURES CORROSIVE FLUIDS	MEDIUM DUTY CYCLE Pressure: See Page 11 Temperature: -260°C - +288°C Velocity: 1,0 m/s max Surface Finish: Ra 0,1-0,4 μm	#700 Unfilled PTFE #716 15% Graphite Filled PTFE #755 Ekonol® filled PTFE #756 Polyimide filled PTFE #771 Mineral, Moly filled PTFE
---	--	--	---

# ROD WIPERS

## SH Wiper

	HEAVY DUTY MOBILE HYDRAULIC	HIGH DUTY CYCLE Temperature: -40°C - +120°C Velocity: 1,0 m/s max Surface Finish: Ra 0,1-0,4 μm	U-1003 LUBRITHANE U-1023 HP LUBRITHANE
---	--------------------------------	--	---

## MC Wiper

	HEAVY DUTY MOBILE HYDRAULIC	HIGH DUTY CYCLE Temperature: -40°C - +120°C Velocity: 1,0 m/s max Surface Finish: Ra 0,1-0,4 μm	U-1023 HP LUBRITHANE
---	--------------------------------	--	----------------------

## H-Wiper

	AGRICULTURAL GENERAL CYLINDER MOBILE HYDRAULIC	MEDIUM DUTY CYCLE Temperature: -40°C - +100°C Velocity: 1,0 m/s max Surface Finish: Ra 0,1-0,4 μm	U-1003 LUBRITHANE
---	--	--	-------------------

## DT-Wiper

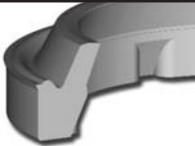
	GENERAL CYLINDER MOBILE HYDRAULIC	HIGH DUTY CYCLE Temperature: -40°C - +120°C Velocity: 1,0 m/s max Surface Finish: Ra 0,1-0,4 μm	U-1003 LUBRITHANE (100°C) U-1023 HP LUBRITHANE
---	--------------------------------------	--	---

# WEAR GUIDES

## WGT Wear Guide

	HEAVY DUTY MOBILE HYDRAULIC	HIGH DUTY CYCLE Temperature: -60°C - +150°C Velocity: 1,0 m/s max Surface Finish: Ra 0,1-0,4 μm	P-2551 GF NYLON P-2552 GF - PTFE Nylon
---	--------------------------------	--	---

## PTFE Wear Guide

	LOW FRICTION GENERAL CYLINDER MOBILE HYDRAULIC GENERAL INDUSTRIAL	HIGH DUTY CYCLE Temperature: -70°C - + 260°C Velocity: 1,0 m/s max Surface Finish: Ra 0,1-0,3 μm	702 15% GLASS, 5% MOLY PTFE 711 25% CARBON GRAPHITE PTFE 714 55% BRONZE, 5% MOLY PTFE 741 40% BRONZE PTFE
---	--	---	--

# PISTON SEALS

## Locking Capped T-Seal

	HEAVY DUTY MOBILE HYDRAULIC	HIGH DUTY CYCLE Pressure: 500 bar Temperature: -40°C - +125°C Velocity: 1,0 m/s max Surface Finish: Ra 0,1-0,4 µm	702 15% GLASS, 5% MOLY PTFE 740 40% BRONZE PTFE A-8501 NITRILE P-2506 NYLON
---	--------------------------------	---	--

## Capped T-Seal®

	HEAVY DUTY MOBILE HYDRAULIC	HIGH DUTY CYCLE Pressure: 500 bar Temperature: -40°C - +125°C Velocity: 1,0 m/s max Surface Finish: Ra 0,1-0,4 µm	702 15% GLASS, 5% MOLY PTFE 740 40% BRONZE PTFE A-8501 NITRILE P-2506 NYLON
---	--------------------------------	---	--

## Grooved Piston Seal

	ACCUMULATORS HEAVY DUTY MOBILE HYDRAULIC GEN. MACHINE	MEDIUM DUTY CYCLE Pressure: 350 bar Temperature: -40°C - +200°C Velocity: 0,5 m/s max Surface Finish: Ra 0,1-0,3 µm	741 40% BRONZE PTFE Customer-Supplied O-Ring and Quad Ring Required.
---	--	---	---

## PTFE Piston Seal

	AGRICULTURAL HEAVY DUTY MOBILE HYDRAULIC GEN. MACHINE	HIGH DUTY CYCLE Pressure: 350 bar Temperature: -40°C - +200°C Velocity: 1,0 m/s max Surface Finish: Ra 0,1-0,4 µm	702 15% GLASS, 5% MOLY PTFE 711 25% CARBON GRAPHITE PTFE 714 55% BRONZE, 5% MOLY PTFE 741 40% BRONZE PTFE Customer Supplied O-Ring Required.
--	--	---	--

## PTFE Piston S-Ring

	MEDIUM OPERATION MOBILE HYDRAULIC	HIGH DUTY CYCLE Pressure: 350 bar Temperature: -40°C - +200°C Velocity: 1,0 m/s max Surface Finish: Ra 0,1-0,4 µm	714 55% BRONZE, 5% MOLY PTFE A-8501 NITRILE Customer Supplied NBR loader required.
---	--------------------------------------	---	--

## Crown Seal®

	AGRICULTURAL HEAVY DUTY MOBILE HYDRAULIC	MEDIUM DUTY CYCLE Pressure: 350 bar Temperature: -40°C - +120°C Velocity: 0,1 m/s max Surface Finish: Ra 0,1-0,4 µm	U-1003 LUBRITHANE (100°C) U-1023 HP LUBRITHANE
---	--	---	---

## Unsymmetrical U-Cup

	AGRICULTURAL GENERAL INDUSTRIAL	MEDIUM DUTY CYCLE Pressure: 350 bar Temperature: -65°C - +120°C Velocity: 0,5 m/s max Surface Finish: Ra 0,1-0,4 µm	U-1003 LUBRITHANE (100°C) U-1023 HP LUBRITHANE
---	------------------------------------	---	---

# Seal Selection

There are many types of Rod and Piston seals available. Many seal types are available in several materials. The products recommended in this manual are the most frequently chosen products. Macrotech Polyseal Inc. engineering personnel can help with choices among a broad range of products including the rod and piston seals described in this manual. Here you will find a general guideline that will assist in the product selection process. For more detailed assistance, please contact a Macrotech Polyseal engineer.

There are nine basic application considerations that may affect your product selection. The nine considerations generally fall in the following sequence.

## 1. Fluid Media

This will determine the types of seal material and seal type that may be suitable for the application. Care should be taken to consider seal types that are available in suitable materials. For use in specific fluids consult with MPI engineering.

## 2. Service Temperature

The minimum and maximum service temperature of the seal and fluids will further determine which materials and seal types are suitable. For general guidelines, refer to the application profiles.

## 3. Pressure/Clearance Gap

The maximum pressure and application extrusion gap will determine the risk of seal extrusion failure in the application. Maximum pressure and clearance gap recommendations are available for each seal type for a variety of temperatures. Basic fluid pressure capability may be determined from the application profiles.

## 4. Leakage and Drift Expectation

Rod seal film control and piston seal drift leakage varies between seal types. Where leakage control is critical, a seal type should be selected that has a high leakage control index. See the charts at the right or contact MPI engineering for assistance.

## 5. Ancillary Performance Criteria

**Friction:** Does the application require a seal with a precise level of friction?

**Stability:** At high linear velocities, seal stability may be an issue. Stability varies between seals.

**Contamination:** Many seal types are somewhat resistant to fluid contamination and solid particles.

Some seal types are easily damaged in poorly controlled environments.

Care should be taken to select among seal types that are resistant to these concerns if they are present in the application.

## 6. Retrofit and Gland Size

Many seal types are available to fit the same gland size. Seal gland size varies among seal types also. Care should be taken to select a seal type that will fit the required existing gland or fit in the space available for a new gland specification.

## 7. Assembly

Some seal types are easily installed without special tools. Other seal types may be more difficult to install. Seals with split anti-extrusion rings may be particularly difficult to install past threads, ports and lock-wire grooves. Consideration should be given to difficulty of installation among seal types.

## 8. Seal Life Expectancy

Performance life will depend on several factors including duty cycle, stroke, speed, pressure, surface finish and fluid type. Seal life will vary between seal types and materials. In general, longer life products will have a greater cost.

## 9. Price and Availability

What suitable seal selection will be the most cost effective for this application?

**Lip/Squeeze Chart:  
Determines friction, wear and sealability**

**Lip Configuration Chart  
Fine tune seal analysis with lip configuration**

# Performance and Leakage Control Index

## Lip Squeeze Chart

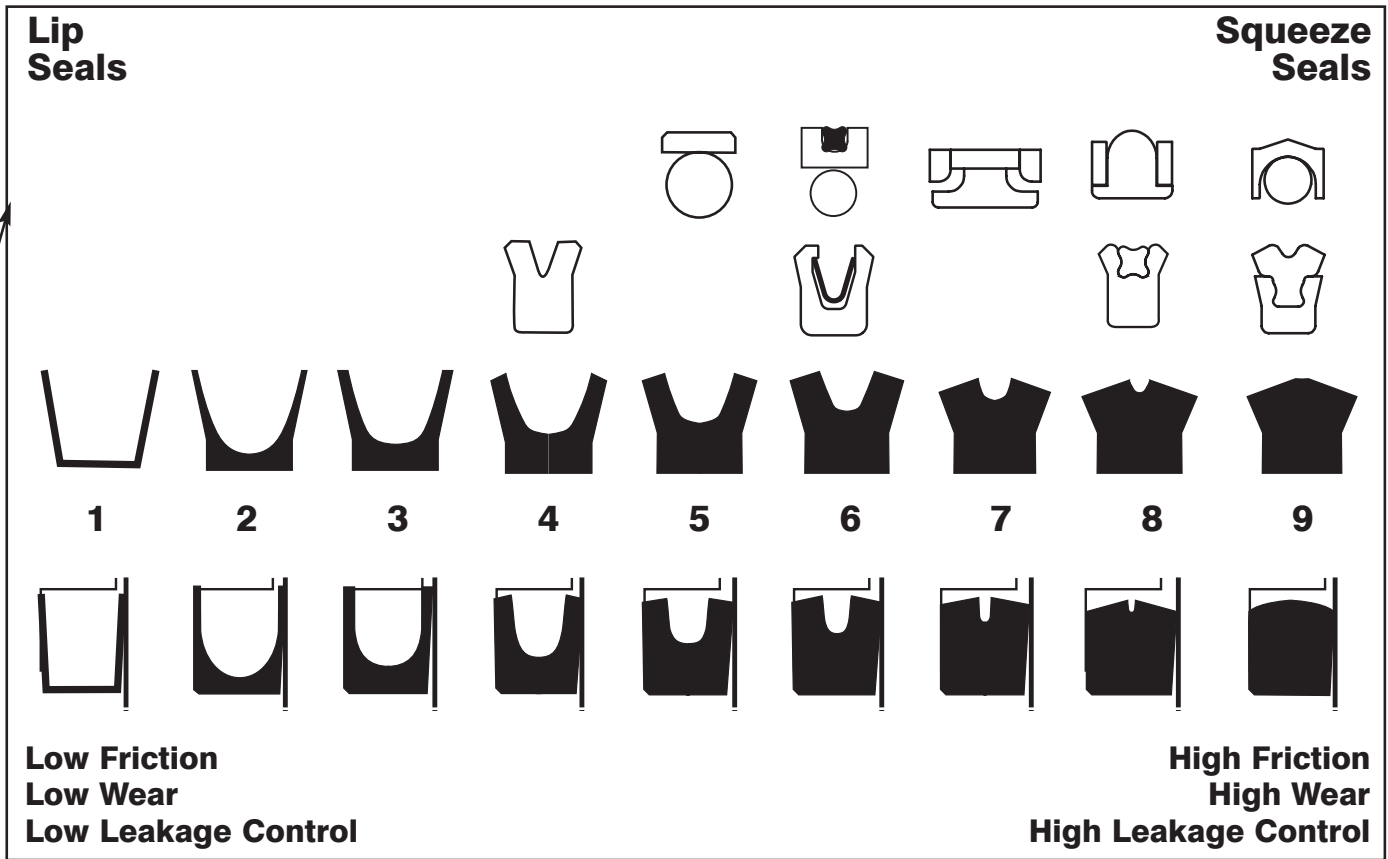

## Lip Configuration Chart

	Sample Seal	Lip Shape	Lip Installed	Pressure Pattern	Leakage Control	Hydroplaning Resistance	Contaminated Environments
1					<b>High</b>	<b>High</b>	<b>Poor</b>
2					<b>High</b>	<b>High</b>	<b>Good</b>
3					<b>Medium</b>	<b>Medium</b>	<b>Poor</b>
4					<b>Low</b>	<b>Low</b>	<b>Good</b>
5					<b>Low</b>	<b>Low</b>	<b>Excellent</b>

# UBR-Polyurethane Rod Seals

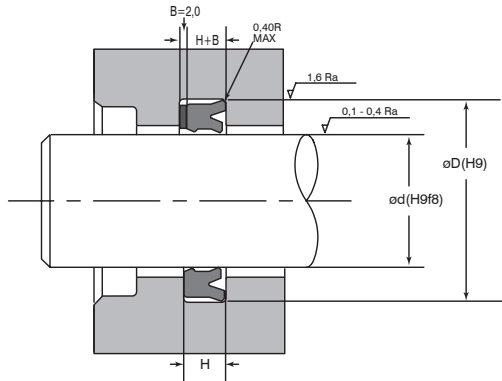

UBR Seal	
HIGH DUTY CYCLE	U-1023 HP LUBRITHANE® U-1028 EXHP LUBRITHANE U-1027 EXHP LUBRITHANE
Pressure: 400 bar	
Temperature: -40°C - 120°C	
Velocity: 1,0 m/s max	
Surface Finish: Ra 0,1-0,4 µm	
Type B Polyseal	
HIGH DUTY CYCLE	U-1003 LUBRITHANE (100°C) U-1023 HP LUBRITHANE U-1028 EXHP LUBRITHANE®
Pressure: 400 bar	
Temperature: -40°C - 120°C	
Velocity: 1,0 m/s max	
Surface Finish: Ra 0,1-0,4 µm	
Deep Z-Seal	
HIGH DUTY CYCLE	U-1003 LUBRITHANE (100°C) U-1023 HP LUBRITHANE U-1028 EXHP LUBRITHANE
Pressure: 400 bar	
Temperature: -40°C - 120°C	
Velocity: 1,0 m/s max	
Surface Finish: Ra 0,1-0,4 µm	
Deep Z with Delta Anti Extrusion Ring	
HIGH DUTY CYCLE	A-8504 LOW-TEMP. NITRILE LIP U-1003 LUBRITHANE BASE (100°C)
Pressure: 400 bar	
Temperature: -54°C - 105°C	
Velocity: 1,0 m/s max	
Surface Finish: Ra 0,1-0,4 µm	

E-Gap	Pressure Bar	
	70°C	90°C
Extrusion Gaps U-1003		
0.10	345	275
0.15	345	225
0.20	310	170
Extrusion Gaps U-1003/Nylon		
0.10	690	690
0.15	690	690
0.20	690	690
Pressure W/WGT's U-1003/Nylon		
0.25	690	490
0.50	410	300
0.75	300	250

## DIMENSIONS

Part Number	I,D.	O,D.	Height	d	D	H	H+B
MPS-01 6-024-05,8 UBR	16	24	5,8	16	24	6,8	8,8
MPS-01 8-026-05,0 UBR	18	26	5,0	18	26	6,0	8,0
MPS-020-026-05,5 UBR	20	26	5,5	20	26	6,5	8,5
MPS-020-028-05,0 UBR	20	28	5,0	20	28	6,0	8,0
MPS-020-030-07,0 UBR	20	30	7,0	20	30	8,0	10,0
MPS-022-030-05,0 UBR	22	30	5,0	22	30	6,0	8,0
MPS-025-033-05,0 UBR	25	33	5,0	25	33	6,0	8,0
MPS-025-035-05,0 UBR	25	35	7,3	25	35	6,0	10,3
MPS-025-035-08,0 UBR	25	35	8,0	25	35	9,0	11,0
MPS-030-040-06,0 UBR	30	40	6,0	30	40	7,0	9,0
MPS-030-045-10,0 UBR	30	45	10,0	30	45	11,0	13,0
MPS-035-045-06,0 UBR	35	45	6,0	35	45	7,0	9,0
MPS-035-045-10,0 UBR	35	45	10,0	35	45	11,0	13,0
MPS-035-050-10,0 UBR	35	50	10,0	35	50	11,0	13,0
MPS-036-046-08,0 UBR	36	46	8,0	36	46	9,0	11,0
MPS-040-050-06,0 UBR	40	50	6,0	40	50	7,0	9,0
MPS-040-050-08,0 UBR	40	50	8,0	40	50	9,0	11,0
MPS-040-055-10,0 UBR	40	55	10,0	40	55	11,0	13,0
MPS-045-055-06,0 UBR	45	55	6,0	45	55	7,0	9,0
MPS-045-055-10,0 UBR	45	55	10,0	45	55	11,0	13,0
MPS-045-060-10,0 UBR	45	60	10,0	45	60	11,0	13,0
MPS-036-046-08,0 UBR	50	60	6,0	50	60	7,0	9,0
MPS-036-046-08,0 UBR	50	60	7,3	50	60	8,3	10,3
MPS-050-060-10,0 UBR	50	60	10,0	50	60	11,0	13,0
MPS-050-060-12,0 UBR	50	60	12,0	50	60	13,0	15,0
MPS-050-063-09,0 UBR	50	63	9,0	50	63	10,0	12,0
MPS-050-065-09,0 UBR	50	65	9,0	50	65	10,0	12,0
MPS-050-065-10,0 UBR	50	65	10,0	50	65	11,0	13,0
MPS-053-063-06,0 UBR	53	63	6,0	53	63	7,0	9,0
MPS-055-065-06,0 UBR	55	65	6,0	55	65	7,0	9,0
MPS-055-070-09,0 UBR	55	70	9,0	55	70	10,0	12,0
MPS-055-075-12,0 UBR	55	75	12,0	55	75	13,0	15,0
MPS-060-070-06,0 UBR	60	70	6,0	60	70	7,0	9,0
MPS-060-070-07,5 UBR	60	70	7,5	60	70	8,5	10,5
MPS-060-070-09,0 UBR	60	70	9,0	60	70	10,0	12,0
MPS-060-070-12,0 UBR	60	70	12,0	60	70	13,0	15,0
MPS-060-075-10,0 UBR	60	75	10,0	60	75	11,0	13,0
MPS-060-076-10,0 UBR	60	76	10,0	60	76	11,0	13,0
MPS-060-080-12,0 UBR	60	80	12,0	60	80	13,0	15,0
MPS-063-073-12,0 UBR	63	73	12,0	63	73	13,0	15,0
MPS-065-075-06,0 UBR	65	75	6,0	65	75	7,0	9,0
MPS-065-075-12,0 UBR	65	75	12,0	65	75	13,0	15,0
MPS-065-080-10,0 UBR	65	80	10,0	65	80	11,0	13,0
MPS-065-085-12,0 UBR	65	85	12,0	65	85	13,0	15,0
MPS-070-080-06,0 UBR	70	80	6,0	70	80	7,0	9,0

## DIMENSIONS

Part Number	I,D.	O,D.	Height	d	D	H	H+B
MPS-070-080-12,0 UBR	70	80	12,0	70	80	13,0	15,0
MPS-070-084-13,0 UBR	70	84	13,0	70	84	14,0	16,0
MPS-070-085-10,0 UBR	70	85	10,0	70	85	11,0	13,0
MPS-070-090-12,0 UBR	70	90	12,0	70	90	13,0	15,0
MPS-075-085-06,0 UBR	75	85	6,0	75	85	7,0	9,0
MPS-075-090-10,0 UBR	75	90	10,0	75	90	11,0	13,0
MPS-075-091-10,0 UBR	75	91	10,0	75	91	11,0	13,0
MPS-075-095-12,0 UBR	75	95	12,0	75	95	13,0	15,0
MPS-080-090-06,0 UBR	80	90	6,0	80	90	7,0	9,0
MPS-080-095-11,4 UBR	80	95	11,4	80	95	12,4	14,4
MPS-080-095-12,5 UBR	80	95	12,5	80	95	13,5	15,5
MPS-080-100-12,0 UBR	80	100	12,0	80	100	13,0	15,0
MPS-085-100-09,0 UBR	85	100	9,0	85	100	10,0	12,0
MPS-085-105-12,0 UBR	85	105	12,0	85	105	13,0	15,0
MPS-090-105-09,0 UBR	90	105	9,0	90	105	10,0	12,0
MPS-090-110-12,0 UBR	90	110	12,0	90	110	13,0	15,0
MPS-095-110-10,0 UBR	95	110	10,0	95	110	11,0	13,0
MPS-095-115-12,0 UBR	95	115	12,0	95	115	13,0	15,0
MPS-100-115-09,0 UBR	100	115	9,0	100	115	10,0	12,0
MPS-100-120-12,0 UBR	100	120	12,0	100	120	13,0	15,0
MPS-105-120-10,0 UBR	105	120	10,0	105	120	11,0	13,0
MPS-105-125-15,0 UBR	105	125	15,0	105	125	16,0	18,0
MPS-110-125-10,0 UBR	110	125	10,0	110	125	11,0	13,0
MPS-110-130-10,0 UBR	110	130	10,0	110	130	11,0	13,0
MPS-112-125-09,0 UBR	112	125	9,0	112	125	10,0	12,0
MPS-120-140-15,0 UBR	120	140	15,0	120	140	16,0	18,0
MPS-125-140-09,0 UBR	125	140	9,0	125	140	10,0	12,0
MPS-125-145-15,0 UBR	125	145	15,0	125	145	16,0	18,0
MPS-130-145-10,0 UBR	130	145	10,0	130	145	11,0	13,0
MPS-130-150-15,0 UBR	130	150	15,0	130	150	16,0	18,0
MPS-136-150-09,0 UBR	136	150	9,0	136	150	10,0	12,0
MPS-140-155-09,0 UBR	140	155	9,0	140	155	10,0	12,0
MPS-140-160-15,0 UBR	140	160	15,0	140	160	16,0	18,0
MPS-145-160-09,0 UBR	145	160	9,0	145	160	10,0	11,0
MPS-150-170-15,0 UBR	150	170	15,0	150	170	16,0	18,0
MPS-155-180-16,0 UBR	155	180	16,0	155	180	17,0	19,0
MPS-165-180-09,5 UBR	165	180	9,5	165	180	10,5	12,5
MPS-180-200-12,5 UBR	180	200	12,5	180	200	13,5	15,5
MPS-180-205-16,0 UBR	180	205	16,0	180	205	17,0	19,0
MPS-200-220-12,5 UBR	200	220	12,5	200	220	13,5	15,5
MPS-225-250-19,0 UBR	225	250	19,0	225	250	20,0	22,0
MPS-230-250-12,5 UBR	230	250	12,5	230	250	13,5	15,5
MPS-250-275-19,0 UBR	250	275	19,0	250	275	20,0	22,0

# Buffer Seals®

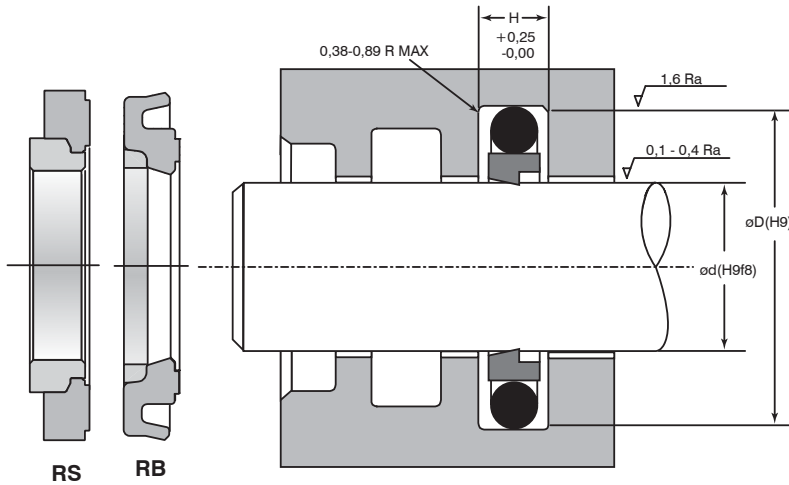

R Style Buffer Seal		
HIGH DUTY CYCLE		741 40% BRONZE PTFE A-8501 NITRILE Customer supplied O-Ring Required.
Pressure:	700 bar	
Temperature:	-54°C - 200°C	
Velocity:	1,0 m/s max	
Surface Finish:	Ra 0,1-0,4 µm	
RB Style Buffer Seal		
HIGH DUTY CYCLE		U-1023 HP LUBRITHANE NYLON ANTI-EXTRUSION U-1027 EXHP LUBRITHANE
Pressure:	700 bar	
Temperature:	-54°C - 120°C	
Velocity:	1,0 m/s max	
Surface Finish:	Ra 0,1-0,4 µm	
RS Style Buffer Seal		
HIGH DUTY CYCLE		74/45% BRONZE PTFE A8501 NITRILE
Pressure:	700 bar	
Temperature:	-54°C - 200°C	
Velocity:	1,0 m/s max	
Surface Finish:	Ra 0,1-0,4 µm	

Buffer seals are positioned inboard from the primary rod seal, protecting the primary rod seal from pressure spikes that may occur in the system. They typically do not provide consistent long-term sealing capabilities, but do filter short pressure spikes from the primary seal, preventing possible extrusion damage to the primary seal.

## Part Number Description

MPS - 050 - 065,1 - 06,3 - R  
 ID OD HT R  
 Rod Groove HT  
 Diameter Diameter Width Style

**Example:** R style buffer seal for a rod diameter of 50 mm, a groove diameter of 65,1mm and a groove width of 6,3mm.

Part Number	d	C/S Series	D	H
MPS-010-17,3-03,2	10	A	17,3	3,2
MPS-015-22,3-03,2	15	A	22,3	3,2
MPS-018-25,3-03,2	18	A	25,3	3,2
MPS-020-27,3-03,2	20	A	27,3	3,2
MPS-025-30,7-04,2	20	B	30,7	4,2
MPS-025-35,7-04,2	25	B	35,7	4,2
MPS-030-40,7-04,2	30	B	40,7	4,2
MPS-036-46,7-04,2	36	B	46,7	4,2
MPS-040-55,1-06,3	40	C	55,1	6,3
MPS-045-60,1-06,3	45	C	60,1	6,3
MPS-050-60,7-04,2	50	B	60,7	4,2
MPS-050-65,1-06,3	50	C	65,1	6,3
MPS-055-70,1-06,3	55	C	70,1	6,3
MPS-060-75,1-06,3	60	C	75,1	6,3
MPS-063-78,1-06,3	63	C	78,1	6,3
MPS-065-80,1-06,3	65	C	80,1	6,3
MPS-070-85,1-06,3	70	C	85,1	6,3
MPS-070-85,5-06,3	70	C	85,5	6,3
MPS-075-90,1-06,3	75	C	90,1	6,3
MPS-075-90,5-06,3	75	C	90,5	6,3
MPS-080-95,1-06,3	80	C	95,1	6,3
MPS-080-95,5-06,3	80	C	95,5	6,3
MPS-085-100,1-06,3	85	C	100,1	6,3
MPS-085-100,5-06,3	85	C	100,5	6,3
MPS-090-105,1-06,3	90	C	105,1	6,3

Part Number	d	C/S Series	D	H
MPS-090-105,5-06,3	90	C	105,5	6,3
MPS-095-110,1-06,3	95	C	110,1	6,3
MPS-095-110,5-06,3	95	C	110,5	6,3
MPS-100-115,1-06,3	100	C	115,1	6,3
MPS-100-115,5-06,3	100	C	115,5	6,3
MPS-105-120,1-06,3	105	C	120,1	6,3
MPS-105-120,5-06,3	105	C	120,5	6,3
MPS-110-125,1-06,3	110	C	125,1	6,3
MPS-110-125,5-06,3	110	C	125,5	6,3
MPS-115-130,1-06,3	115	C	130,1	6,3
MPS-115-130,5-06,3	115	C	130,5	6,3
MPS-120-135,1-06,3	120	C	135,1	6,3
MPS-125-140,1-06,3	125	C	140,1	6,3
MPS-125-140,5-06,3	125	C	140,5	6,3
MPS-130-145,1-06,3	130	C	145,1	6,3
MPS-130-145,5-06,3	130	C	145,5	6,3
MPS-135-150,1-06,3	135	C	150,1	6,3
MPS-135-150,5-06,3	135	C	150,5	6,3
MPS-140-155,1-06,3	140	C	155,1	6,3
MPS-140-155,5-06,3	140	C	155,5	6,3
MPS-150-165,1-06,3	150	C	165,1	6,3
MPS-150-165,5-06,3	150	C	165,5	6,3
MPS-160-175,1-06,3	160	C	175,1	6,3
MPS-160-175,5-06,3	160	C	175,5	6,3
MPS-170-185,1-06,3	170	C	185,1	6,3

Part Number	d	C/S Series	D	H
MPS-170-185,5-06,3	170	C	185,5	6,3
MPS-180-195,1-06,3	180	C	195,1	6,3
MPS-180-195,5-06,3	180	C	195,5	6,3
MPS-190-205,1-06,3	190	C	205,1	6,3
MPS-190-205,5-06,3	190	C	205,5	6,3
MPS-200-220,5-08,1	200	D	220,5	8,1
MPS-200-221-08,0	200	D	221	8
MPS-210-230,5-08,1	210	D	230,5	8,1
MPS-210-231-08,0	210	D	231	8
MPS-220-240,5-08,1	220	D	240,5	8,1
MPS-230-250,5-08,1	230	D	250,5	8,1
MPS-240-260,5-08,1	240	D	260,5	8,1
MPS-250-270,5-08,1	250	D	270,5	8,1
MPS-260-284-08,1	260	D	284	8,1
MPS-270-294-08,1	270	D	294	8,1
MPS-280-304-08,1	280	D	304	8,1
MPS-290-314-08,1	290	D	314	8,1
MPS-300-324-08,1	300	D	324	8,1
MPS-310-334-08,1	310	D	334	8,1
MPS-320-344-08,1	320	D	344	8,1
MPS-330-354-08,1	330	D	354	8,1
MPS-340-364-08,1	340	D	364	8,1
MPS-350-374-08,1	350	D	374	8,1

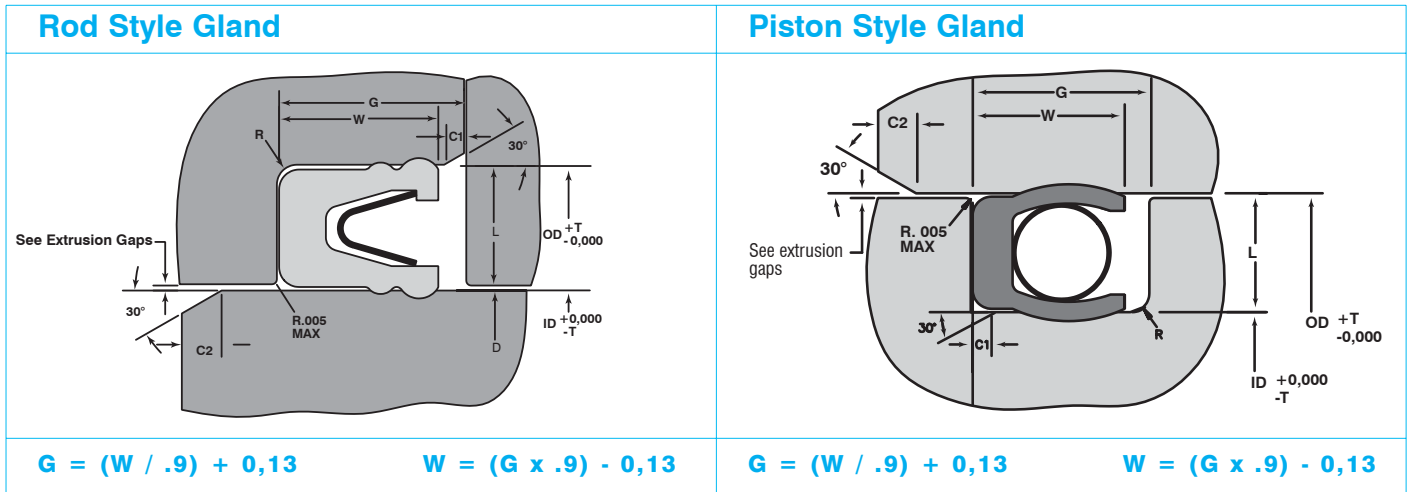

HELICAL WOUND SPRING									
Std. L. Dim	L. Range	G. +0,25/-0,00	W. ± 0,13	R. Max.	Min. I.D.	Suggested Max I.D.	T Dim	C1 +0,13/-0,00	C2 Min.
1,6	1,52/2,03	MIN = 2,24 STD = 2,39 HVY = 3,79	MIN = 1,91 STD = 2,03 HVY = 3,28	0,25	2,36	89	0,05	0,20	0,51
2,39	2,26/2,64	MIN = 3,10 STD = 3,56 HVY = 4,65	MIN = 2,67 STD = 3,07 HVY = 4,06	0,30	3,18	140	0,05	0,25	0,76
3,18	3,07/3,45	MIN = 4,09 STD = 4,75 HVY = 5,97	MIN = 3,56 STD = 4,14 HVY = 5,23	0,38	6,35	165	0,05	0,38	1,02
4,78	4,72/5,16	MIN = 6,05 STD = 7,14 HVY = 8,49	MIN = 5,33 STD = 6,30 HVY = 7,52	0,51	12,70	241	0,08	0,56	1,27
6,35	6,05/6,88	MIN = 7,80 STD = 9,53 HVY = 12,07	MIN = 6,91 STD = 8,46 HVY = 10,74	0,89	22,23	495	0,08	0,76	2,03

CANTILEVER SPRING									
Std. L. Dim	L. Range	G. +0,25/-0,00	W. ± 0,13	R. Max.	Min. I.D.	Suggested Max I.D.	T DIM	C1 +0,13/-0,00	C2 Min.
1,6	1,40/2,16	STD = 2,39 HVY = 3,79	STD = 2,03 HVY = 3,28	0,25	3,81	89	0,05	0,20	0,51
2,39	2,18/2,79	MIN = 3,18 STD = 3,56 HVY = 4,65	MIN = 2,74 STD = 3,07 HVY = 4,06	0,30	6,35	140	0,05	0,25	0,76
3,18	2,82/3,73	MIN = 3,78 STD = 4,75 HVY = 5,97	MIN = 3,30 STD = 4,14 HVY = 5,23	0,38	7,62	165	0,05	0,38	1,02
4,78	3,76/5,77	MIN = 4,88 STD = 7,14 HVY = 8,48	MIN = 4,27 STD = 6,30 HVY = 7,52	0,51	12,07	241	0,08	0,56	1,27
6,35	5,79/7,95	MIN = 7,32 STD = 9,53 HVY = 12,07	MIN = 6,48 STD = 8,46 HVY = 10,74	0,89	25,40	368	0,08	0,76	2,03
9,53	7,98/11,13	MIN = 9,88 STD = 12,06 HVY = 15,29	MIN = 8,79 STD = 10,74 HVY = 13,64	1,02	31,75	495	0,10	1,02	2,54

### Part Number Description

MSS - X B 03,18 - 063,5 - 04,06 - A - 776

ID Lip Style    OD Lip Style    Gland Cross section L Dim    Rod or Gland DIA    Seal Height W Dim    Spring Material    Seal Jacket

Standard cross-sections are shown in column Std. L. Dim. Non-standard cross-sections should fit within the possible range shown in column L. Range. Column T. Dim. shows tolerances for Standard glands and non-standard glands.

Columns G and W provide typical gland heights and corresponding seal heights. The Min. G and W dimensions can be used when axial space is a concern. This gland and seal height should not be used at higher pressures where seal extrusion would be a concern. Std. G and W dimensions are similar to the gland heights required for elastomer O-Rings. This seal height offers improved extrusion resistance. Hvy. G and W dimensions are for severe applications where high pressures and high temperatures could cause excessive extrusion of the seal.

The Part numbering system allows you to specify a specific seal height as long as it meets the minimum height requirements provided in column W in charts at left.

Please consult with Macrotech Polyseal Engineering Department for design recommendations if your gland dimensions do not fit within the possible cross-section range, or your gland width (G Dim.) does not meet Macrotech Polyseal minimum width requirements. A non-standard design could possibly be offered to fit your existing gland dimensions.

Seal Lip Styles		Advantages	Disadvantages
<b>A</b> (Cantilever Spring / Single Radius)		<ul style="list-style-type: none"> <li>Low wear rate</li> <li>Oscillatory, slow rotary applications.</li> <li>Radius Lip reduces seal lip damage during installation.</li> </ul>	<ul style="list-style-type: none"> <li>Should not be used for dynamic sealing of abrasive media.</li> <li>May weep in high speed reciprocating applications due to seal lip hydroplaning.</li> </ul>
<b>B</b> (Cantilever Spring / Beveled Lip)		<ul style="list-style-type: none"> <li>Improved sealability, preferred design for dynamic sealing of gas/vapors.</li> <li>Lip reduces seal lip damage during installation.</li> </ul>	<ul style="list-style-type: none"> <li>Should not be used for dynamic sealing of abrasive media.</li> <li>May weep in high speed reciprocating applications due to seal lip hydroplaning.</li> </ul>
<b>D</b> (Cantilever Spring / Scraper Lip)		<ul style="list-style-type: none"> <li>Locks seal into reduced glands.</li> <li>Reduced probability of seal lip hydroplaning.</li> <li>Low wear rate.</li> <li>Good excluder for debris/contamination.</li> </ul>	<ul style="list-style-type: none"> <li>Requires good lead-in chamfer if hardware is installed lip first.</li> <li>Possible weepage of light fluids or gases.</li> </ul>
<b>S</b> (Cantilever Spring / Double Radius)		<ul style="list-style-type: none"> <li>Low wear rate.</li> <li>Redundant seal lip design.</li> <li>Trapped fluid between contact points provide added lubrication to seal.</li> </ul>	<ul style="list-style-type: none"> <li>Should not be used for dynamic sealing of abrasive media.</li> <li>May weep in high speed reciprocating applications due to seal lip hydroplaning.</li> </ul>
<b>X</b> (Cantilever Spring / Improved Scraper Lip)		<ul style="list-style-type: none"> <li>Improved sealability over D style lip.</li> <li>Preferred lip design for dynamic sealing of abrasive media.</li> <li>Reduced probability of seal lip hydroplaning.</li> </ul>	<ul style="list-style-type: none"> <li>Requires good lead-in chamfer if hardware is installed lip first.</li> <li>Lip design must be used in combination with other lip style.</li> </ul>
<b>H</b> (Helical Wound Spring / Radius Lip)		<ul style="list-style-type: none"> <li>High load of helical wound spring improves sealability.</li> <li>Suitable for sealing cryogenic gases and fluids.</li> <li>Radius Lip reduces seal lip damage during installation.</li> </ul>	<ul style="list-style-type: none"> <li>Should not be used for dynamic sealing of abrasive media.</li> <li>May weep in high speed reciprocating applications due to seal lip hydroplaning.</li> </ul>
<b>W</b> (Helical Wound Spring / Scraper Lip)		<ul style="list-style-type: none"> <li>High load of helical wound spring improves sealability.</li> <li>Preferred lip design for dynamic sealing of abrasive media.</li> <li>Reduced probability of seal lip hydroplaning</li> </ul>	<ul style="list-style-type: none"> <li>Requires good lead-in chamfer if hardware is installed lip first.</li> <li>Lip design must be used in combination with radius lip style.</li> </ul>

### Seal Extrusion

Rod Seal Extrusion	Increased Heel Thickness	Use of Back-up Ring

High pressure can cause the seal jacket material to flow into the extrusion gap in the hardware resulting in distortion of the seal causing leakage and/or premature seal failure. Higher temperatures and dynamics increase the possibility of extrusion. Increasing the heel thickness behind the spring will prevent extrusion in many cases. For demanding applications, a back up ring produced from a stronger material such as Nylon, Acetal or PEEK might be used to prevent extrusion.

Maximum Extrusion Gaps at Various Pressures and Temperatures							
Seal C/S	Degrees C	35 BAR	69 BAR	207 BAR	345 BAR	517 BAR	689 BAR
1,60	To 95	0,15	0,13	0,08	0,05		
	To 150	0,13	0,10	0,05			
	To 200	0,10	0,08				
	To 260	0,08	0,05				
2,39	To 95	0,23	0,18	0,10	0,05	0,05	
	To 150	0,20	0,15	0,05			
	To 200	0,18	0,10	0,05			
	To 260	0,13	0,05				
3,18	To 95	0,30	0,25	0,13	0,08	0,05	
	To 150	0,28	0,20	0,08	0,05		
	To 200	0,25	0,13	0,05			
	To 260	0,15	0,08				
4,78	To 95	0,46	0,41	0,15	0,10	0,08	0,05
	To 150	0,43	0,30	0,10	0,05	0,05	
	To 200	0,33	0,18	0,05			
	To 260	0,20	0,10				
6,35	To 95	0,64	0,58	0,20	0,13	0,08	0,05
	To 150	0,58	0,36	0,13	0,08	0,05	
	To 200	0,43	0,20	0,08	0,05		
	To 260	0,25	0,13	0,05			

Consult Macrotech Polyseal Engineering

This table provides the maximum recommended extrusion gaps for filled PTFE SpectraSeals at various temperatures and pressures. If your application exceeds these conditions please consult with Macrotech Polyseal Engineering Department for design assistance. Extrusion Gaps based on standard seal widths and the use of filled PTFE for the seal jacket material. When using unfilled PTFE, gaps should be reduced to the next higher pressure rating.

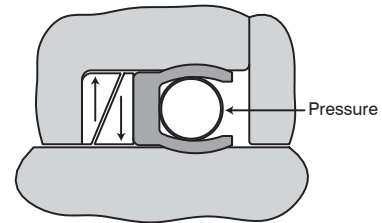

### Delta Backup Rings

Seal design for extreme pressures utilizing Delta type Backup rings to bridge extrusion gap. Pressure load energizes backup rings eliminating extrusion gap. This type of Back Up Ring is frequently used in high pressure piston applications where there is a potential of cylinder growth. Delta back up rings are typically manufactured from high strength plastic materials such as Nylon, Acetal or PEEK.

# Spectraseal® Seal Jacket Compounds

EXTRUSION RELIABILITY	Spectraloy Compound #	Temperature Rating (°C)	Wear Resistance	Chemical Resistance	Mating Surface Hardness	Compound Features and Recommended Service
	700	-268°C +232°C	P	E	A	Unfilled PTFE: Used predominately for static or slow speed/intermittent service. Excellent for cryogenic service.
	716	-268°C +260°C	F	E	A	15% Graphite filled PTFE: Very low coefficient of friction. Used in low-pressure dynamic applications that are friction sensitive.
	755	-268°C +288°C	G	G	A	*EkonoI® filled PTFE: Good wear resistance but is not abrasive against nonhardened surfaces. Should not be used in steam applications.
	756	-268°C +288°C	E	G	A	Polyimide filled PTFE: Excellent wear resistance but is not abrasive against non-hardened surfaces. Should not be used in steam applications.
	771	-268°C +288°C	E	G	B	Mineral, Moly filled PTFE: Excellent wear resistance. Typically used for dynamic sealing at higher temperatures and pressures.
	721	-268°C +288°C	G	G	B	Mineral filled PTFE: Filler is an FDA approved mineral. Used for sealing food products at temperatures greater than 80°C.
	734	-268°C +288°C	G	E	B	10% Carbon Graphite filled PTFE: General-purpose material. Suitable for dynamic sealing of steam and water.
	702	-268°C +288°C	E	E	C	Glass, Moly filled PTFE: Excellent material for dynamic sealing at high temperatures and pressures.
	703	-268°C +288°C	E	E	C	PPS, Carbon and Moly filled PTFE: Excellent wear rate in non-lubricated service at high temperatures and pressures.
	782	-268°C +288°C	E	E	C	Carbon Fiber filled PTFE: Excellent wear and creep resistance at elevated temperatures. Good abrasion resistance for sealing non-lubricating media at elevated temperatures.
	711	-268°C +288°C	E	E	C	25% Carbon Graphite filled PTFE: Similar to #734 but additional filler improves wear, creep and extrusion resistance.
	741	-268°C +288°C	E	P	B	40% Bronze filled PTFE: Suited for high-speed dynamic sealing of lubricating media. Should not be used for chemical service.
	776	-268°C +80°C	E	G	A	UHMWPE: FDA and USDA approved. Best material for reciprocating service in water or water based fluids. Typically used for food products, paints, adhesives, and resins. Excellent abrasion resistance.
	745	-73°C +288°C	G	G	B	Unfilled PEEK: High strength material predominately used for back-up rings. Suitable for sealing non-lubricating, viscous fluids from ambient to 288°C.
Material Comparison: E = Excellent    G = Good    F = Fair    P = Poor						

\*Elgiloy is a registered trade mark of Elgiloy Limited Partnership. All rights reserved.

\*EkonoI is a registered trade mark of Carborundum Company. All rights reserved.

Spring Materials			
Spring Type	301 Stainless	17-7 PH Stainless	*Elgiloy
Cantilever	✓✓✓		✓✓✓
Helical Wound		✓✓✓	✓✓✓

Rockwell Hardness			
Velocity Meters Per Second	< 30 RC	45 RC	58 RC
0-.25	A or B	A, B or C	A, B or C
.26-.50	A	A or B	A, B or C
.51+	A	A or B	A or B

\* While Stainless Steel 301 and 17-7 PH are suitable for most applications, \*Elgiloy®, which is a Cobalt Nickel Alloy, is a premium grade material. This material offers improved load deflection and chemical resistance. Elgiloy meets the requirements of NACE (National Association Of Corrosion Engineers).

Consult Macrotech Polyseal Engineering for recommendations for rotary sealing at speeds greater than 1.5 meters per second.

# Press-fit Wipers

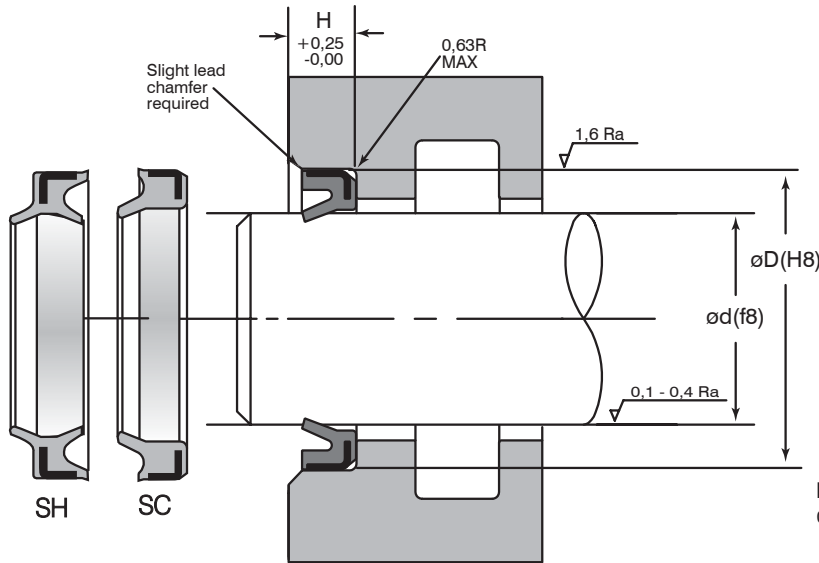

## MC Wiper & SH Wiper

HIGH DUTY CYCLE	U-1023 HP LUBRITHANE®
Temperature: -40°C - 120°C	U-1003 LUBRITHANE
Velocity: 1.0 m/s max	(100°C)
Surface Finish: Ra 0,1-0,4 μm	

## Part Number Description

MPS	-	020	-	032	-	06	-	MC
		ID Rod Diameter		OD Groove Diameter		HT Groove Width		Style

**Example:** MC style wiper for a rod diameter of 20 mm, a groove diameter of 32 mm and a groove width of 6 mm.

Part Number	Rod Dia d	Groove Dia D	Groove Width H
MPS-020-032-06	20	32	6
MPS-030-042-06	30	42	6
MPS-035-047-07	35	47	7
MPS-040-052-07	40	52	7
MPS-045-057-07	45	57	7
MPS-050-062-07	50	62	7
MPS-055-069-08	55	69	8
MPS-060-074-08	60	74	8
MPS-065-079-08	65	79	8
MPS-070-084-08	70	84	8
MPS-075-089-08	75	89	8
MPS-080-094-08	80	94	8
MPS-085-099-08	85	99	8
MPS-090-104-08	90	104	8
MPS-095-109-08	95	109	8
MPS-100-114-08	100	114	8
MPS-105-121-09	105	121	9
MPS-110-126-09	110	126	9
MPS-120-136-09	120	136	9
MPS-130-146-09	130	146	9
MPS-140-160-10	140	160	10
MPS-150-170-10	150	170	10
MPS-160-180-10	160	180	10

**Metal Clad Wipers (MC).** The MC series contains a Lubrithane element encased in a metal retainer, providing mechanical bonding because the element overlaps a portion of the retainer as well as a good chemical bond. High quality steel metal retaining ring of the proper wall thickness provides adequate strength for the various diameters. The wiper is rigid enough to handle the toughest of scraping environments such as dry/wet mud and ice, yet sensitive enough to exclude fine dust and moisture.

**SC Self Cleaning Wiper.** Specifically designed lip keeps mud, cement and other similar substances from hardening in the wiper. The RL style wiper lip provides a reduction in apparent rod seal leakage while maintaining equivalent ingress resistance to a sharp lip wiper.

**SH Wiper** One piece press-in type rod wiper designed for medium duty applications. Secondary U-Cup. The RL style wiper lip provides a reduction in apparent rod seal leakage while maintaining equivalent ingress resistance to a sharp lip wiper.

# Snap-in Wipers

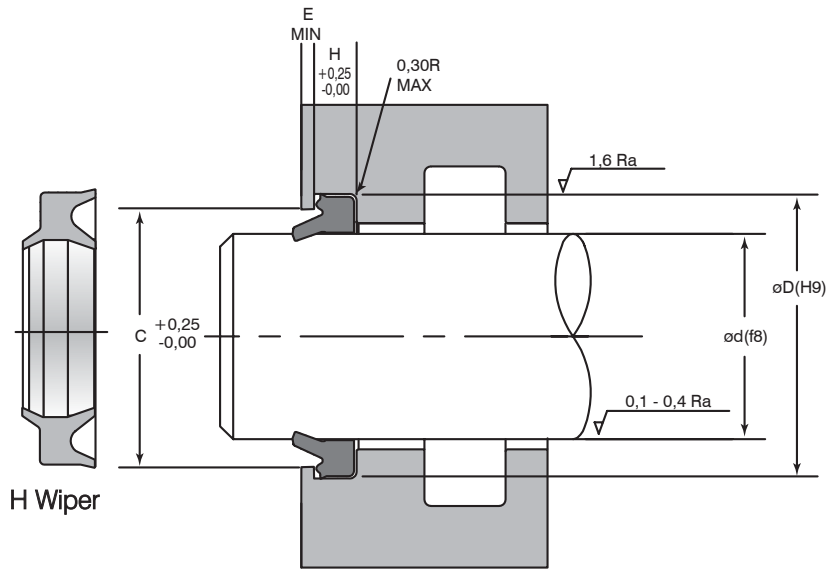

Part Number	Rod Dia d	Groove Dia D	Groove Width H	C	E
MPS-016-024-04,5	16	24	5	20	2
MPS-018-026-04,5	18	26	5	22	2
MPS-020-028-04,5	20	28	5	24	2
MPS-022-030-04,5	22	30	5	26	2
MPS-022,4-030,4-04,5	22,4	30,4	5	26,4	2
MPS-025-033-04,5	25	33	5	29	2
MPS-028-036-04,5	28	36	5	32	2
MPS-030-038-05,0	30	38	6	34	2
MPS-31,5-39,5-05,0	31,5	39,5	6	35,5	2
MPS-032-040-05,0	32	40	6	36	2
MPS-035-043-05,0	35	43	6	39	2
MPS-35,5-43,5-05,0	35,5	43,5	6	39,5	2
MPS-036-044-05,0	36	44	6	40	2
MPS-040-048-05,0	40	48	6	44	2
MPS-045-053-05,0	45	53	6	49	2
MPS-050-058-05,0	50	58	6	54	2
MPS-055-063-05,0	55	63	6	59	2
MPS-056-064-05,0	56	64	6	60	2
MPS-060-068-05,0	60	68	6	64	2
MPS-063-071-05,0	63	71	6	67	2
MPS-065-073-05,0	65	73	6	69	2
MPS-070-080-06,0	70	80	7	75	3
MPS-071-081-06,0	71	81	7	76	3
MPS-075-085-06,0	75	85	7	80	3
MPS-080-090-06,0	80	90	7	85	3
MPS-085-095-06,0	85	95	7	90	3
MPS-090-100-06,0	90	100	7	95	3
MPS-095-105-06,0	95	105	7	100	3
MPS-100-110-06,0	100	110	7	105	3
MPS-112-122-06,0	112	122	7	117	3
MPS-125-153-07,0	125	138	8	132	3
MPS-140-153-07,0	140	153	8	147	3

H Wiper		
MEDIUM DUTY CYCLE		
Temperature:	-40°C - 100°C	U-1003 LUBRITHANE®
Velocity:	1,0 m/s max	
Surface Finish:	Ra 0,1-0,4 µm	
DT Wiper		
HIGH DUTY CYCLE		
Temperature:	-40°C - 120°C	U-1003 LUBRITHANE (100°C)
Velocity:	1,0 m/s max	U-1023 HP LUBRITHANE
Surface Finish:	Ra 0,1-0,4 µm	

## Part Number Description

MPS - 025 - 033 - 04,5 - DT  
 ID                      OD                      HT                      Style  
 Rod                      Groove                      Groove  
 Diameter                      Diameter                      Width

**Example:** DT style wiper for a rod diameter of 25 mm, a groove diameter of 33mm and a groove width of 5mm.

**DT (Slotted) Wiper.** This wiper is ideal for most applications including contaminated environments.

**H Wiper.** These are one-piece snap-in type rod wipers designed for light duty applications. The U Cup portion of these wipers serves as a secondary safeguard against leakage past the primary rod seal. H Wipers are not pressure seals.

# O-Ring Energized Piston Rings

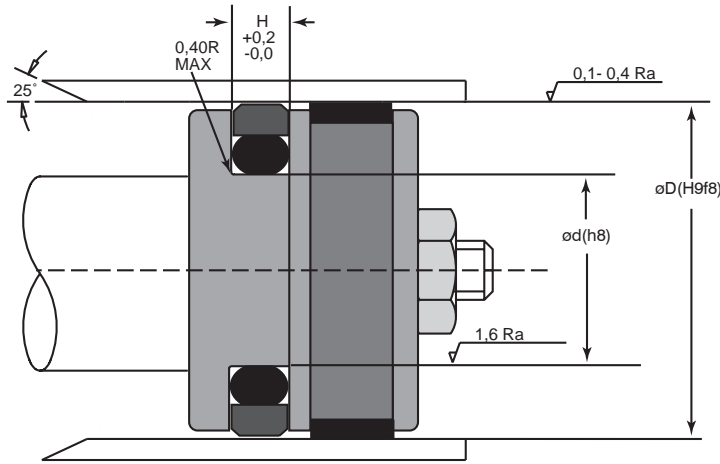

## Maximum Extrusion Gaps

Series	0-100 Bar	200 Bar	400 Bar
A	0,75	0,40	0,25
B	0,80	0,50	0,23
C	0,90	0,70	0,40
D	1,00	0,70	0,50

## PTFE Piston Seal

HIGH DUTY CYCLE		702 15% GLASS, 5% MOLY PTFE
Pressure	350 bar	711 25% CARBON GRAPHITE PTFE
Temperature	-40°C - 200°C	714 55% BRONZE, 5% MOLY PTFE
Velocity	1.0 m/s max	741 40% BRONZE PTFE
Surface Finish	Ra 0,1-0,4 µm	Distributor Supplied O-Ring Required

## Materials

No.	Description	Recommended Service
702	15% Glass, 5% Moly	General Purpose
716	15% Graphite	Low Friction
741	40% Bronze	General Purpose
711	25% Carbon Graphite	High Temperatures and Pressures

## Part Number Description

MPS - A - 020,0 - PRO - 702

Series/ Bore Piston Ring Material  
Cross Diamater O Ring Energized  
Section

Part Number	Series	D	d	H	O-Ring Size
MPS-A-020,0-PRO	A	20	12,5	3,2	112
MPS-A-022,0-PRO	A	22	14,5	3,2	113
MPS-A-025,0-PRO	A	25	17,5	3,2	115
MPS-A-028,0-PRO	A	28	20,5	3,2	117
MPS-A-030,0-PRO	A	30	22,5	3,2	118
MPS-A-035,0-PRO	A	35	27,5	3,2	121
MPS-B-040,0-PRO	B	40	29	4,2	216
MPS-B-042,0-PRO	B	42	31	4,2	217
MPS-B-045,0-PRO	B	45	34	4,2	219
MPS-B-050,0-PRO	B	50	39	4,2	222
MPS-B-055,0-PRO	B	55	44	4,2	224
MPS-B-060,0-PRO	B	60	49	4,2	225
MPS-B-063,0-PRO	B	63	52	4,2	226
MPS-B-065,0-PRO	B	65	54	4,2	227
MPS-B-070,0-PRO	B	70	59	4,2	228
MPS-B-075,0-PRO	B	75	64	4,2	230
MPS-C-070,0-PRO	C	70	54,5	6,3	330
MPS-C-080,0-PRO	C	80	64,5	6,3	333
MPS-C-085,0-PRO	C	85	69,5	6,3	335
MPS-C-090,0-PRO	C	90	74,5	6,3	336
MPS-C-100,0-PRO	C	100	84,5	6,3	340
MPS-C-105,0-PRO	C	105	89,5	6,3	341
MPS-C-110,0-PRO	C	110	94,5	6,3	342
MPS-C-115,0-PRO	C	115	99,5	6,3	344
MPS-C-120,0-PRO	C	120	104,5	6,3	346
MPS-C-125,0-PRO	C	125	109,5	6,3	347
MPS-C-130,0-PRO	C	130	114,5	6,3	349
MPS-C-132,0-PRO	C	132	116,5	6,3	349
MPS-D-080,0-PRO	D	80	59	8,1	407
MPS-D-085,0-PRO	D	85	64	8,1	409
MPS-D-100,0-PRO	D	100	79	8,1	414
MPS-D-105,0-PRO	D	105	84	8,1	415

Part Number	Series	D	d	H	O-Ring Size
MPS-D-110,0-PRO	D	110	89	8,1	417
MPS-D-115,0-PRO	D	115	94	8,1	418
MPS-D-120,0-PRO	D	120	99	8,1	420
MPS-D-125,0-PRO	D	125	104	8,1	421
MPS-D-130,0-PRO	D	130	109	8,1	423
MPS-D-135,0-PRO	D	135	114	8,1	425
MPS-D-140,0-PRO	D	140	119	8,1	426
MPS-D-145,0-PRO	D	145	124	8,1	428
MPS-D-150,0-PRO	D	150	129	8,1	429
MPS-D-155,0-PRO	D	155	134	8,1	431
MPS-D-160,0-PRO	D	160	139	8,1	432
MPS-D-165,0-PRO	D	165	144	8,1	434
MPS-D-170,0-PRO	D	170	149	8,1	435
MPS-D-175,0-PRO	D	175	154	8,1	437
MPS-D-180,0-PRO	D	180	159	8,1	438
MPS-D-190,0-PRO	D	190	169	8,1	439
MPS-D-200,0-PRO	D	200	179	8,1	441
MPS-D-210,0-PRO	D	210	189	8,1	442
MPS-D-220,0-PRO	D	220	199	8,1	444
MPS-D-230,0-PRO	D	230	209	8,1	445
MPS-D-240,0-PRO	D	240	219	8,1	446
MPS-D-250,0-PRO	D	250	229	8,1	447
MPS-D-260,0-PRO	D	260	239	8,1	447
MPS-D-270,0-PRO	D	270	249	8,1	448
MPS-D-280,0-PRO	D	280	259	8,1	449
MPS-D-290,0-PRO	D	290	269	8,1	450
MPS-D-300,0-PRO	D	300	279	8,1	451
MPS-D-310,0-PRO	D	310	289	8,1	451
MPS-D-320,0-PRO	D	320	299	8,1	452
MPS-D-330,0-PRO	D	330	309	8,1	453
MPS-D-340,0-PRO	D	340	319	8,1	454
MPS-D-350,0-PRO	D	350	329	8,1	454

Note: O-Ring energizer required. Contact Macrotech Polyseal Inc. distributor.

# Square-Ring Energized Piston Rings

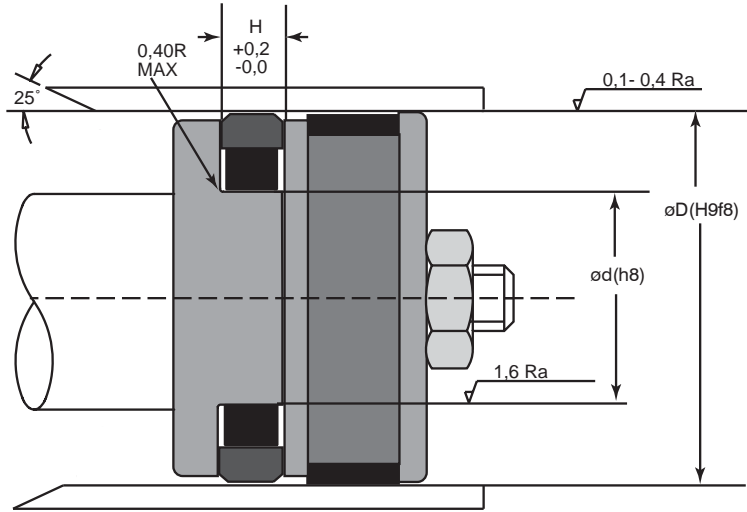

Maximum Extrusion Gaps			
Series	0-100 Bar	200 Bar	400 Bar
A	0,75	0,40	0,25
B	0,80	0,50	0,23
C	0,90	0,70	0,40
D	1,00	0,70	0,50

PTFE Piston S-Ring	
HIGH DUTY CYCLE Pressure: 350 bar Temperature: -40°C - 200°C Velocity: 1.0 m/s max Surface Finish: Ra 0,1-0,4 µm	741 40% BRONZE PTFE Distributor-supplied Square-Ring required.

Part Number	Series	øD	ød	H	Square Ring Size
MPS-A-050,0-PRS	A	50	40	4,5	-222
MPS-A-055,0-PRS	A	55	45	4,5	-224
MPS-A-056,0-PRS	A	56	46	4,5	-224
MPS-A-060,0-PRS	A	60	50	4,5	-225
MPS-B-063,0-PRS	B	63	48	7,5	-328
MPS-B-065,0-PRS	B	65	50	7,5	-329
MPS-B-070,0-PRS	B	70	55	7,5	-330
MPS-B-075,0-PRS	B	75	60	7,5	-332
MPS-B-080,0-PRS	B	80	65	7,5	-333
MPS-B-085,0-PRS	B	85	70	7,5	335
MPS-B-090,0-PRS	B	90	75	7,5	336
MPS-B-095,0-PRS	B	95	80	7,5	338
MPS-B-100,0-PRS	B	100	85	7,5	340
MPS-C-110,0-PRS	C	110	94	7,5	342
MPS-C-112,0-PRS	C	112	96	7,5	343
MPS-C-116,0-PRS	C	116	100	7,5	344
MPS-C-118,0-PRS	C	118	102	7,5	345
MPS-C-120,0-PRS	C	120	104	7,5	346
MPS-C-125,0-PRS	C	125	109	7,5	347
MPS-C-130,0-PRS	C	130	114	7,5	349
MPS-C-140,0-PRS	C	140	124	7,5	352
MPS-C-150,0-PRS	C	150	134	7,5	355
MPS-C-160,0-PRS	C	160	144	7,5	358
MPS-D-170,0-PRS	D	170	148	11	435
MPS-D-180,0-PRS	D	180	158	11	438
MPS-D-190,0-PRS	D	190	168	11	439
MPS-D-200,0-PRS	D	200	178	11	441
MPS-D-204,0-PRS	D	204	182	11	441
MPS-D-210,0-PRS	D	210	188	11	442
MPS-D-220,0-PRS	D	220	198	11	444
MPS-D-224,0-PRS	D	224	202	11	444
MPS-D-225,0-PRS	D	225	203	11	445
MPS-D-230,0-PRS	D	230	208	11	445
MPS-D-240,0-PRS	D	240	218	11	446

## Part Number Description

MPS	-	A	-	050,0	-	PRS	-	702
		Series/ Cross Section		Bore Diameter		Piston Ring Square Ring Energized		Material

## Materials

No.	Description	Recommended Service
702	15% Glass, 5% Moly	General Purpose
716	15% Graphite	Low Friction
741	40% Bronze	General Purpose
711	25% Carbon Graphite	High Temperatures and Pressures

Note: Square Ring energizer required. Contact Macrotech Polyseal Inc. distributor.

# Crown Piston Seal®

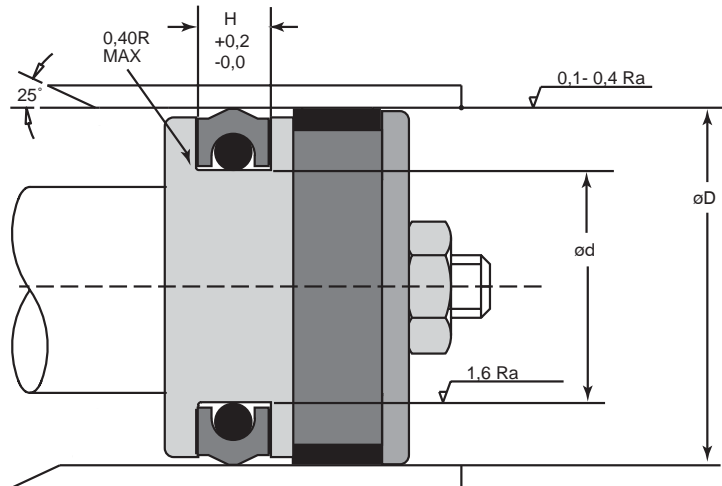

E-Gap	Pressure Bar	
	70°C	90°C
Extrusion Gaps U-1003		
0.10	345	275
0.15	345	225
0.20	310	170

Part Number	D	Tol.	d	Tol.	H
MPS-022-028-CPV	28	+0,08/0	22	0/-,08	4,7
MPS-024-030-CPV	30	+0,08/0	24	0/-,08	4,7
MPS-026-032-CPV	32	+0,08/0	26	0/-,08	4,7
MPS-029-035-CPV	35	+0,08/0	29	0/-,08	4,7
MPS-032-038-CPV	38	+0,08/0	32	0/-,08	4,7
MPS-034-040-CPV	40	+0,08/0	34	0/-,08	4,7
MPS-036-042-CPV	42	+0,08/0	36	0/-,08	4,7
MPS-039-045-CPV	45	+0,08/0	39	0/-,08	4,7
MPS-042-048-CPV	48	+0,08/0	42	0/-,08	4,7
MPS-044-050-CPV	50	+0,08/0	44	0/-,08	4,7
MPS-042-052-CPV	52	+0,10/0	42	0/-,10	7,5
MPS-045-055-CPV	55	+0,10/0	45	0/-,10	7,5
MPS-050-060-CPV	60	+0,10/0	50	0/-,10	7,5
MPS-053-063-CPV	63	+0,10/0	53	0/-,10	7,5
MPS-055-065-CPV	65	+0,10/0	55	0/-,10	7,5
MPS-060-070-CPV	70	+0,10/0	60	0/-,10	7,5
MPS-065-075-CPV	75	+0,10/0	65	0/-,10	7,5
MPS-070-080-CPV	80	+0,10/0	70	0/-,10	7,5
MPS-075-085-CPV	85	+0,10/0	75	0/-,10	7,5
MPS-080-090-CPV	90	+0,10/0	80	0/-,10	7,5
MPS-085-095-CPV	95	+0,10/0	85	0/-,10	7,5
MPS-090-100-CPV	100	+0,10/0	90	0/-,10	7,5
MPS-095-105-CPV	105	+0,10/0	95	0/-,10	7,5
MPS-100-110-CPV	110	+0,10/0	100	0/-,10	7,5
MPS-105-115-CPV	115	+0,10/0	105	0/-,10	7,5
MPS-110-120-CPV	120	+0,10/0	110	0/-,10	7,5
MPS-115-125-CPV	125	+0,10/0	115	0/-,10	7,5
MPS-120-130-CPV	130	+0,10/0	120	0/-,10	7,5
MPS-125-135-CPV	135	+0,10/0	125	0/-,10	7,5
MPS-130-140-CPV	140	+0,10/0	130	0/-,10	7,5
MPS-135-145-CPV	145	+0,10/0	135	0/-,10	7,5
MPS-140-150-CPV	150	+0,10/0	140	0/-,10	7,5
MPS-140-155-CPV	155	+0,10/0	140	0/-,10	11
MPS-145-160-CPV	160	+0,10/0	145	0/-,10	11
MPS-150-165-CPV	165	+0,10/0	150	0/-,10	11
MPS-155-170-CPV	170	+0,10/0	155	0/-,10	11
MPS-160-175-CPV	175	+0,10/0	160	0/-,10	11
MPS-165-180-CPV	180	+0,10/0	165	0/-,10	11
MPS-170-185-CPV	185	+0,10/0	170	0/-,10	11
MPS-175-190-CPV	190	+0,10/0	175	0/-,10	11
MPS-180-195-CPV	195	+0,10/0	180	0/-,10	11
MPS-185-200-CPV	200	+0,10/0	185	0/-,10	11
MPS-190-205-CPV	205	+0,10/0	190	0/-,10	11
MPS-195-210-CPV	210	+0,10/0	195	0/-,10	11
MPS-200-215-CPV	215	+0,10/0	200	0/-,10	11
MPS-205-220-CPV	220	+0,10/0	205	0/-,10	11
MPS-210-225-CPV	225	+0,10/0	210	0/-,10	11
MPS-215-230-CPV	230	+0,10/0	215	0/-,10	11

## Crown Seal

MEDIUM DUTY CYCLE	U-1003 LUBRITHANE (100°C)
Pressure: 350 bar	U-1023 HP LUBRITHANE
Temperature: -40°C - 120°C	
Velocity: 0,1 m/s max	
Surface Finish: Ra 0,1-0,4 µm	

## Part Number Description

MPS	-	022	-	028	-	CPV
		Groove Diameter		Bore Diameter		Style

The Crown Seal® is a squeeze -type seal. An O-ring is used as a loading spring and to seal the static surface. The crowned sealing surface produces positive seal from vacuum to high pressure, due to narrow single line seal contact area. Crown Seal side legs act as an anti-extrusion device for the O-ring as well as adding stability to the seal. The dynamic sealing element of the Crown Seal can be made of either Lubrithane or Fluorotrel to give long life on relatively rough sealing surfaces. Crown Seal is double acting, requiring only one groove on the piston.

Crown seals are designed as bi-directional piston seals. They are also used frequently in slow speed rotary service.

# Polyurethane Piston Seals

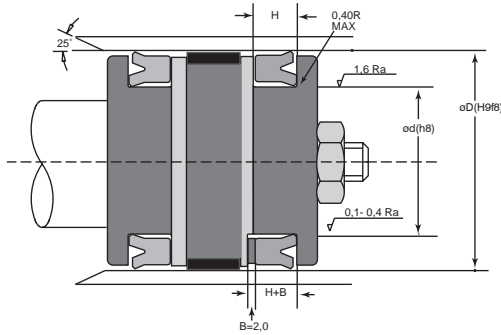
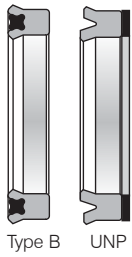

UBR Seal	
HIGH DUTY CYCLE	U-1023 HP LUBRITHANE® U-1028 EXHP LUBRITHANE U-1027 EXHP LUBRITHANE
Pressure:	400 bar
Temperature:	-40°C - 120°C
Velocity:	1,0 m/s max
Surface Finish:	Ra 0,1-0,4 $\mu$ m
Type B Polyseal	
HIGH DUTY CYCLE	U-1003 LUBRITHANE (100°C) U-1023 HP LUBRITHANE U-1028 EXHP LUBRITHANE
Pressure:	400 bar
Temperature:	-40°C - 120°C
Velocity:	1,0 m/s max
Surface Finish:	Ra 0,1-0,4 $\mu$ m
Deep Z-Seal	
HIGH DUTY CYCLE	U-1003 LUBRITHANE (100°C) U-1023 HP LUBRITHANE U-1028 EXHP LUBRITHANE
Pressure:	400 bar
Temperature:	-40°C - 120°C
Velocity:	1,0 m/s max
Surface Finish:	Ra 0,1-0,4 $\mu$ m
Deep Z with Delta Anti Extrusion Ring	
HIGH DUTY CYCLE	A-8504 LOW-TEMP. NITRILE LIP U-1003 LUBRITHANE® BASE P-2506
Pressure:	400 bar
Temperature:	-54°C - 105°C
Velocity:	1,0 m/s max
Surface Finish:	Ra 0,1-0,4 $\mu$ m

E-Gap	Pressure Bar	
	70°C	90°C
Extrusion Gaps U-1003		
0.10	345	275
0.15	345	225
0.20	310	170
Extrusion Gaps U-1003/Nylon		
0.10	690	690
0.15	690	690
0.20	690	690
Pressure W/WGT's U-1003/Nylon		
0.25	690	490
0.50	410	300
0.75	300	250

Part Number	Dimensions						
	I.D.	O.D.	Height	d	D	H	H+B
MPS-09-019-08,0-UNP	9	19	8,0	9,0	19,0	8,8	10,8
MPS-011,2-019,2-05,0-UNP	11,2	19,2	5,0	11,2	19,2	5,5	7,5
MPS-012,5-022,5-08,0-UNP	12,5	22,5	8,0	12,5	22,5	8,8	10,8
MPS-014-022-05,0-UNP	14	22	5,0	14,0	22,0	5,5	7,5
MPS-014-024-08,0-UNP	14	24	8,0	14,0	24,0	8,8	10,8
MPS-015-025-08,0-UNP	15	25	8,0	15,0	25,0	8,8	10,8
MPS-016-024-05,0-UNP	16	24	5,0	16,0	24,0	5,5	7,5
MPS-016-026-08,0-UNP	16	26	8,0	16,0	26,0	8,8	10,8
MPS-018-026-05,0-UNP	18	26	5,0	18,0	26,0	5,5	7,5
MPS-020-028-05,0-UNP	20	28	5,0	20,0	28,0	5,5	7,5
MPS-020-030-08,0-UNP	20	30	8,0	20,0	30,0	8,8	10,8
MPS-022,4-030-05,0-UNP	22,4	30	5,0	22,4	30,0	5,5	7,5
MPS-022,4-032,4-08,0-UNP	22,4	32	8,0	22,4	32,4	8,8	10,8
MPS-023,5-031,5-05,0-UNP	23,5	31	5,0	23,5	31,5	5,5	7,5
MPS-025-033-05,0-UNP	25	33	5,0	25,0	33,0	5,5	7,5
MPS-025-035-08,0-UNP	25	35	8,0	25,0	35,0	8,8	10,8
MPS-028-040-10,0-UNP	28	40	10,0	28,0	40,0	11,0	13,0
MPS-028-043-10,2-UNP	28	43	10,2	28,0	43,0	11,22	13,22
MPS-030-040-06,0-UNP	30	40	6,0	30,0	40,0	6,6	8,6
MPS-030-045-10,0-UNP	30	45	10,0	30,0	45,0	11,0	12,0
MPS-031,5-041,5-06,0-UNP	31,5	41,5	6,0	31,5	41,5	6,6	8,6
MPS-035-045-06,0-UNP	35	45	6,0	35,0	45,0	6,6	8,6
MPS-035-050-10,0-UNP	35	50	10,0	35,0	50,0	11,0	13,0
MPS-035,5-045-06,0-UNP	35,5	45	6,0	35,5	45,0	6,6	8,6
MPS-040-050-06,0-UNP	40	50	6,0	40,0	50,0	6,6	8,6
MPS-040-055-10,0-UNP	40	55	10,0	40,0	55,0	11,0	13,0
MPS-045-055-06,0-UNP	45	55	6,0	45,0	55,0	6,6	8,6
MPS-045-056-07,0-UNP	45	56	7,0	45,0	56,0	7,7	9,7
MPS-045-060-10,0-UNP	45	60	10,0	45,0	60,0	11,0	13,0
MPS-048-063-10,0-UNP	48	63	10,0	48,0	63,0	11,0	13,0
MPS-050-060-06,0-UNP	50	60	6,0	50,0	60,0	6,6	8,6
MPS-050-065-10,0-UNP	50	65	10,0	50,0	65,0	11,0	12,0
MPS-053-063-06,0-UNP	53	63	6,0	53,0	63,0	6,6	8,6
MPS-055-065-06,0-UNP	55	65	6,0	55,0	65,0	6,6	8,6
MPS-055-075-12,0-UNP	55	75	12,0	55,0	75,0	13,2	15,2
MPS-056-066-06,0-UNP	56	66	6,0	56,0	66,0	6,6	8,6
MPS-060-070-06,0-UNP	60	70	6,0	60,0	70,0	6,6	8,6
MPS-060-071-07,0-UNP	60	71	7,0	60,0	71,0	7,7	9,7
MPS-060-080-12,0-UNP	60	80	12,0	60,0	80,0	13,2	15,2
MPS-065-075-06,0-UNP	65	75	6,0	65,0	75,0	6,6	8,6
MPS-065-085-12,0-UNP	65	85	12,0	65,0	85,0	13,2	15,2
MPS-067-077-06,0-UNP	67	77	6,0	67,0	77,0	6,6	8,6
MPS-070-080-06,0-UNP	70	80	6,0	70,0	80,0	6,6	8,6
MPS-070-090-12,0-UNP	70	90	12,0	70,0	90,0	13,2	15,2

Part Number	Dimensions						
	I.D.	O.D.	Height	d	D	H	H+B
MPS-071-080-06,0-UNP	71	80	6,0	71,0	80,0	6,6	8,6
MPS-080-090-06,0-UNP	80	90	6,0	80,0	90,0	6,6	8,6
MPS-080-100-12,0-UNP	80	100	12,0	80,0	100,0	13,2	15,2
MPS-085-100-09,0-UNP	85	100	9,0	85,0	100,0	9,9	11,9
MPS-085-105-12,0-UNP	85	105	12,0	85,0	105,0	13,2	15,2
MPS-090-105-09,0-UNP	90	105	9,0	90,0	105,0	9,9	11,9
MPS-090-110-12,0-UNP	90	110	12,0	90,0	110,0	13,2	15,2
MPS-095-110-09,0-UNP	95	110	9,0	95,0	110,0	9,9	11,9
MPS-100-115-09,0-UNP	100	115	9,0	100,0	115,0	9,9	11,9
MPS-100-120-12,0-UNP	100	120	12,0	100,0	120,0	13,2	15,2
MPS-110-130-15,0-UNP	110	130	15,0	110,0	130,0	16,5	18,5
MPS-110-125-09,0-UNP	110	125	9,0	110,0	125,0	9,9	11,9
MPS-120-140-15,0-UNP	120	140	15,0	120,0	140,0	16,5	18,5
MPS-125-140-09,0-UNP	125	140	9,0	125,0	140,0	9,9	11,9
MPS-125-145-15,0-UNP	125	145	15,0	125,0	145,0	16,5	18,5
MPS-130-150-16,0-UNP	130	150	15,0	130,0	150,0	17,6	19,6
MPS-136-150-09,0-UNP	136	150	9,0	136,0	150,0	9,9	11,9
MPS-140-155-09,0-UNP	140	155	9,0	140,0	155,0	9,9	11,9
MPS-140-160-16,0-UNP	140	160	15,0	140,0	160,0	17,6	19,6
MPS-145-160-16,0-UNP	145	160	16,0	145,0	160,0	17,6	19,6
MPS-150-170-16,0-UNP	150	170	15,0	150,0	170,0	17,6	19,6
MPS-155-180-16,0-UNP	155	180	16,0	155,0	180,0	17,6	19,6
MPS-160-185-16,0-UNP	160	185	16,0	160,0	185,0	17,6	19,6
MPS-165-180-10,0-UNP	165	180	9,0	165,0	180,0	11,0	11,9
MPS-165-190-16,0-UNP	165	190	16,0	165,0	190,0	17,6	19,6
MPS-170-195-16,0-UNP	170	195	16,0	170,0	195,0	17,6	19,6
MPS-175-200-16,0-UNP	175	200	16,0	175,0	200,0	17,6	19,6
MPS-180-200-16,0-UNP	180	200	12,5	180,0	200,0	17,6	19,6
MPS-180-205-16,0-UNP	180	205	16,0	180,0	205,0	17,6	19,6
MPS-190-215-16,0-UNP	190	215	16,0	190,0	215,0	17,6	19,6
MPS-199-224-16,0-UNP	199	224	16,0	199,0	224,0	17,6	19,6
MPS-200,220-16,0-UNP	200	220	12,5	200,0	220,0	17,6	19,6
MPS-200-225-16,0-UNP	200	225	16,0	200,0	225,0	17,6	19,6
MPS-204-224-16,0-UNP	204	224	12,5	204,0	224,0	17,6	19,6
MPS-212-237-19,0-UNP	212	237	19,0	212,0	237,0	20,9	22,9
MPS-224-249-19,0-UNP	224	249	19,0	224,0	249,0	20,9	22,9
MPS-225-250-19,0-UNP	225	250	19,0	225,0	250,0	20,9	22,9
MPS-230-250-16,0-UNP	230	250	12,5	230,0	250,0	17,6	19,6
MPS-230-255-19,0-UNP	230	255	19,0	230,0	255,0	20,9	22,9
MPS-236-261-19,0-UNP	236	261	19,0	236,0	261,0	20,9	22,9
MPS-250-275-19,0-UNP	250	275	19,0	250,0	275,0	20,9	22,9
MPS-265-295-19,0-UNP	265	295	19,0	265,0	295,0	20,9	22,9
MPS-270-300-19,0-UNP	270	300	19,0	270,0	300,0	20,9	22,9
MPS-280-310-19,0-UNP	280	310	19,0	280,0	310,0	20,9	22,9
MPS-300-330-19,0-UNP	300	330	19,0	300,0	330,0	20,9	22,9

# Grooved Piston Rings

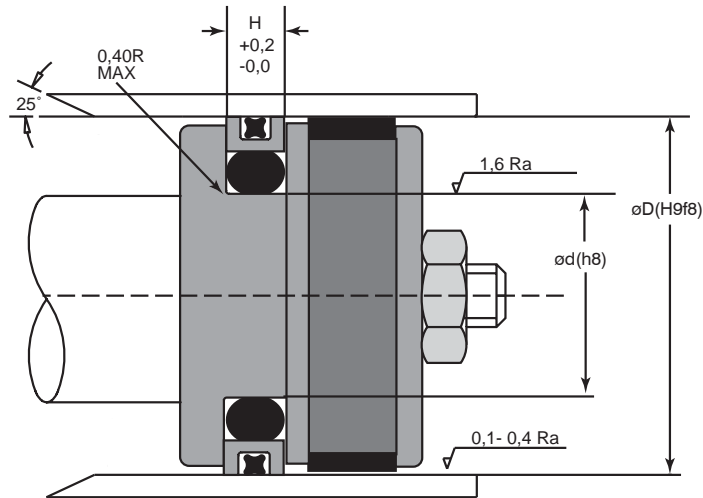

Maximum Extrusion Gaps			
Series	0-100 Bar	200 Bar	400 Bar
B	0,46	0,15	0,10
C	0,61	0,20	0,13
D	0,76	0,25	0,15

## Grooved Piston Seal

HIGH SPEED		741 40% BRONZE PTFE
Pressure:	350 bar	Distributor-Supplied O-Ring and Quad Ring Required.
Temperature:	-40°C - 200°C	
Velocity:	0.5 m/s max	
Surface Finish:	Ra 0,1-0,3 $\mu$ m	

## Elastomer Components

Part Number	Series	D	d	H	Loader Size	Dynamic Size
MPS-B-020,0 GPR	B	20	9	4,2	-204	4-016
MPS-B-022,0 GPR	B	22	11	4,2	-205	4-018
MPS-B-025,0 GPR	B	25	14	4,2	-207	4-020
MPS-B-028,0 GPR	B	28	17	4,2	-209	4-022
MPS-B-030,0 GPR	B	30	19	4,2	-210	4-023
MPS-B-035,0 GPR	B	35	24	4,2	-213	4-026
MPS-B-040,0-GPR	B	40	29	4,2	-216	4-028
MPS-B-042,0-GPR	B	42	31	4,2	-217	4-029
MPS-B-045,0-GPR	B	45	34	4,2	-219	4-030
MPS-B-050,0-GPR	B	50	39	4,2	-222	4-031
MPS-B-055,0-GPR	B	55	44	4,2	-224	4-033
MPS-B-060,0-GPR	B	60	49	4,2	-225	4-034
MPS-B-063,0-GPR	B	63	52	4,2	-226	4-035
MPS-B-065,0-GPR	B	65	54	4,2	-227	4-036
MPS-B-070,0-GPR	B	70	59	4,2	-228	4-038
MPS-B-075,0-GPR	B	75	64	4,2	-230	4-039
MPS-B-080,0-GPR	B	80	69	4,2	-231	4-041
MPS-C-085,0-GPR	C	85	69,5	6,3	-335	4-151
MPS-C-090,0-GPR	C	90	74,5	6,3	-336	4-152
MPS-C-095,0-GPR	C	95	79,5	6,3	-338	4-153
MPS-C-100,0-GPR	C	100	84,5	6,3	-339	4-154
MPS-C-105,0-GPR	C	105	89,5	6,3	-341	4-154
MPS-C-110,0-GPR	C	110	94,5	6,3	-342	4-155
MPS-C-115,0-GPR	C	115	99,5	6,3	-344	4-156
MPS-C-120,0-GPR	C	120	104,5	6,3	-345	4-157
MPS-C-125,0-GPR	C	125	109,5	6,3	-347	4-157
MPS-C-130,0-GPR	C	130	114,5	6,3	-348	4-158
MPS-C-132,0-GPR	C	132	116,5	6,3	-349	4-159
MPS-C-135,0-GPR	C	135	119,5	6,3	-350	4-159
MPS-C-140,0-GPR	C	140	124,5	6,3	-352	4-160
MPS-C-145,0-GPR	C	145	129,5	6,3	-353	4-161
MPS-C-150,0-GPR	C	150	134,5	6,3	-355	4-161
MPS-C-155,0-GPR	C	155	139,5	6,3	-356	4-162
MPS-D-160,0-GPR	D	160	139	8,1	-432	4-258
MPS-D-165,0-GPR	D	165	144	8,1	-434	4-259
MPS-D-170,0-GPR	D	170	149	8,1	-435	4-259
MPS-D-175,0-GPR	D	175	154	8,1	-437	4-260
MPS-D-180,0-GPR	D	180	159	8,1	-438	4-261
MPS-D-190,0-GPR	D	190	169	8,1	-439	4-262

## Part Number Description

MPS - B - 020,0 - GPR - 702

Series/ Cross Section    Bore Diameter    Grooved Piston Ring    Material

## Materials

No.	Description	Recommended Service
702	15% Glass, 5% Moly	General Purpose
716	15% Graphite	Low Friction
741	40% Bronze	General Purpose
711	25% Carbon Graphite	High Temperatures and Pressures

Note: Elastomer components required. Contact Macrotech Polyseal Inc. distributor.

# Capped-T Piston Seal®

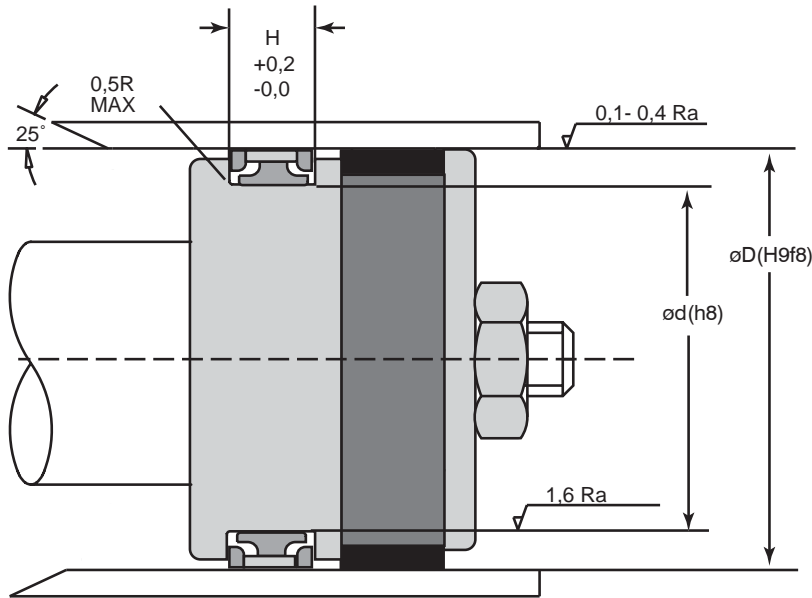

Extrusion Gaps U-1003/Nylon		
0.10	690	690
0.15	690	690
0.20	690	690
Pressure W/WGT's U-1003/Nylon		
0.25	690	490
0.50	410	300
0.75	300	250

## Capped T Piston Seal®

<b>HIGH DUTY CYCLE</b>		702 15% GLASS, 5% MOLY PTFE
Pressure:	500 bar	741 40% BRONZE PTFE
Temperature:	-40°C - 125°C	A-8501 NITRILE
Velocity:	1,0 m/s max	P-2506 NYLON
Surface Finish:	Ra 0,1-0,4 µm	

Part Number	Bore D	Gland d	Gland Length H
CT-050-MK	50	36	9
CT-060-MK	60	46	9
CT-065-MK	65	50	11
CT-070-MK	70	55	11
CT-080-MK	80	65	11
CT-085-MK	85	70	11
CT-090-MK	90	75	11
CT-095-MK	95	80	11
CT-100-MK	100	85	12.5
CT-105-MK	105	90	12.5
CT-110-MK	110	95	12.5
CT-115-MK	115	100	12.5
CT-120-MK	120	105	12.5
CT-125-MK	125	102	16
CT-130-MK	130	107	16
CT-135-MK	135	112	16
CT-140-MK	140	117	16
CT-145-MK	145	122	16
CT-150-MK	150	127	16
CT-160-MK	160	137	16
CT-165-MK	165	142	16
CT-170-MK	170	147	16
CT-180-MK	180	157	16
CT-185-MK	185	162	16
CT-190-MK	190	167	16
CT-200-MK	200	177	16
CT-210-MK	210	187	16
CT-220-MK	220	197	16
CT-225-MK	225	202	16
CT-230-MK	230	207	16
CT-240-MK	240	217	16
CT-250-MK	250	222	17.5
CT-260-MK	260	232	17.5
CT-270-MK	270	242	17.5

## Part Number Description

CT - 050 - MK - 702 - A8501 - P-2506

Bore Diameter                      Cap Material                      Energizer Material                      Backup Material

## Materials

### Cap Rings

#### PTFE Compounds

No.	Description	Temp	Recommended Service
702	15% Glass, 5% Moly	-73°C to +232°C	General Purpose hydraulic, hydrocarbon and water.
711	25% Carbon Graphite		High pressure hydraulic, hydrocarbon and water, Low friction.
714	55% bronze 5% moly		High speed, pressure and abrasion resistance
741	40% bronze		High Temperatures and Pressures
721	mineral, moly		Long wear, General Purpose

PTFE is inert to most fluids, however the fillers may be affected by certain fluids. If suitability is in doubt, please contact Polyseal engineering Dept.

### Energizers

#### Elastomers

A-8501	NBR Nitrile	70Aduro	-37°C + 129°C	General purpose hydraulic and hydrocarbon fluid service.
A-8504	NBR Nitrile	70A duro	-54°C + 115°C	Low temperature hydraulic fluid service.
V-7501	FKM Fluoroelastomer	70A duro	-28°C + 204°C	High temperature and harsh media applications: hydrocarbons and di-esters.

### Anti Extrusion Ring

#### Plastics

P-2506	Reinforced Nylon	-40°C + 107°C	General purpose hydraulic, hydrocarvon service
745	PEEK virgin	-40°C + 232°C	Extended temperature, pressure and media resistance.

\* Temperature ranges shown are limited by the functional range of the CT assembly. Materials shown may have different operating ranges when used in other seal designs. The information contained herein is based on laboratory tests believed to be reliable. It is offered for comparison and guidance to persons who will conduct their own test in order to determine suitability for any purpose.

# Macrotech Polyseal, Inc. Material Selection Chart



Material	Fluid Compatibility							Recommended Temperature Range by Polymer								
	Water	Water Based Hydraulic Fluid	Petroleum Oil	Phosphate Ester Based Fluid	DOT 3 Brake Fluid	Silicon Based Fluid	Other	-100	-50	0	50	100	150	200	250	
Nitrile A-8501	R	R	R	N	N	R	C			-37°C	130°C					
P2551, P2552	R	R	R	R	R	R	C			-29°C	204°C					
Standard Lubrithane U-1003	S	S	R	N	N	R	C			-54°C	93°C	105°C				
Extended Range Lubrithane U-1023 U-1028	S	S	R	N	N	R	C			-54°C	105°C	120°C				
PTFE (Polytetrafluoroethylene)	R	R	R	R	R	R	C			See Page 12						288°C
Fluorotrel	S	S	R	R	R	R	C			-54°C	145°C					

■ = intermittent

- R** Recommended, little or no effect.
- S** Serviceable, moderate effect.  
Do not use above 60°C
- N** Not recommended, severe effect.
- C** Contact Macrotech Polyseal Inc. for Specific Assistance

Refer to the Fluid Sealing Association technical handbook or contact Macrotech Polyseal Engineering for more specific information.

# Close Tolerance Wear Guides

## Available in 3 Joint Styles



## 0,05 Total Thickness Range

Polyseal Close Tolerance Wear Guides are carefully manufactured to ensure precision clearance control in fluid power systems. This provides longer seal life in dynamic systems.

Reinforced nylon wear guides prevent metal-to-metal contact, allowing metal components to be selected without fear of scoring damage to sealing surfaces.

Close tolerance control assures minimum clearances and maximum bearing contact to eliminate deflection under load. Macrotech Polyseal Process Control and Quality Assurance provide state-of-the-art repeatability.

## Part Numbering Guide

MPS - 080 - 086 - 050 - WGT  
I.D. O.D. Nominal Width Style

Example: nominal size, 80mm ID x 86 mm OD  
C/S thickness tolerance: 3,00/2,95

## Piston Application Groove Dimensions

1. Subtract 0,03 mm from minimum bore (B min) to allow for ovality and assembly clearance.
2. Subtract twice maximum Wear Guide thickness (T max). The result is the maximum groove diameter (G max).
3. Subtract piston machining tolerance to obtain G min.
4. To G minimum, add twice minimum Wear Guide thickness (T min) to obtain minimum installed Wear Guide O.D.
5. Subtract twice minimum desired radial piston-to-bore clearance to obtain maximum piston diameter (P max). Subtract piston machining tolerance to obtain P min.
6. Groove Length (L) is equal to nominal Wear Guide width (W) plus 0,25/0,50

## Seal Extrusion Gap

Maximum seal extrusion gap (E max) without cylinder bore expansion can be estimated by:

$$E \max = B \max - (G \min + T \min + \frac{P \min - G \min}{2})$$

## Example

Example bore is 50,000/50,08. Wear Guide is 3,0/2,95 thick and 15mm wide. Piston machining tolerance is a total of 0,05. Minimum desired radial piston-to-bore clearance is 0,25.

1.  $50,00 - 0,03 = 49,97$
2.  $49,97 - (2 \times 3,0) = 43,97$  (G max)
3.  $43,97 - 0,05 = 43,92$  (G min)
4.  $43,92 + (2 \times 2,95) = 49,82$
5.  $49,82 - (2 \times 0,25) = 49,32$  (P max)  
 $49,32 - 0,05 = 49,27$  (P min)
6.  $15,00 + (0,25/0,50) = 15,25/15,50$

## Seal Extrusion Gap

$$50,08 - (43,92 + 2,95 + \frac{49,27 - 43,92}{2}) = 0,54$$

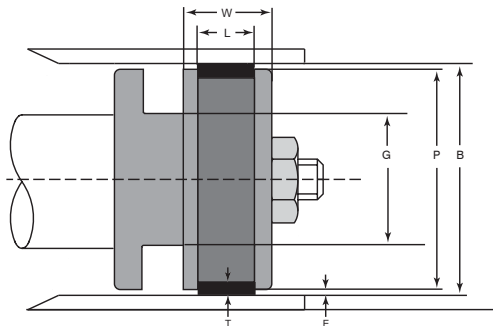

## Materials

No.	Description	Temp.	Recommended Service
P-2551	40% Glass Filled Nylon	- 240 °C +150 °C	General Hydraulic (lubed)
P-2552	40% Glass Filled Nylon, with PTFE	- 240 °C +150 °C	General Hydraulic and Pneumatic, non-lubed

## Typical Physical Properties Glass Reinforced Nylon P-2551

Property	ASTM		
	Test	P-2551	P-2552
Tensile Strength, MPa	D638	172	158
Elongation, %	D638	3.0	2
Flexural Modulus, MPa	D790	9650	9300
Compressive Strength, MPa	D695	158	138
IZOD Impact Strength, J/m Notched 3,18mm x 6,36 mm	D256	133	107
Hardness, Rockwell R	D795	120	120
Water Absorption, %	D570		
24 Hrs.		1.2%	1.0%
Continuous Immersion		5.0	4.0

## Rod Application Groove Dimensions

1. Add 0,03 mm from maximum rod (R max) to allow for assembly.
2. Add twice maximum Wear Guide thickness (T max). The result is the minimum groove diameter (D min).
3. Add machining tolerance to obtain D max.
4. From D max, subtract twice the minimum Wear Guide thickness (T min) to obtain maximum installed Wear Ring I.D.
5. Add twice the minimum desired radial rod-to-gland bore clearance to obtain minimum gland bore diameter (H min). Add gland machining tolerance to obtain H max.
6. Groove length (L) is equal to nominal Wear Guide width (W) plus .025/0,50 mm.

## Seal Extrusion Gap

Maximum seal extrusion gap (F max) for new assembly can be estimated by:

$$E \max = (H \max + D \max - 2H \min) - (T \min + R \min)$$

## Example

Example rod is 25,00/24,95. Wear Guide is 3,0/2,95 thick and 10 wide. Rod Gland machining tolerance is a total of 0,50. Minimum desired rod-to-gland clearance is 0,25.

1.  $25,03 + 0,03 = 25,03$
2.  $25,03 + (2 \times 3,0) = 31,03$  (D min)
3.  $31,03 + 0,05 = 31,08$  (D max)
4.  $31,08 - (2 \times 2,95) = 25,18$
5.  $25,18 + (2 \times 0,25) = 25,68$  (H min)  
 $25,68 + 0,05 = 25,73$  (H max)
6.  $10,00 + (0,25/0,50) = 10,25/10,50$

## Seal Extrusion Gap

$$(25,73 + \frac{31,08 - 25,73}{2}) - (2,95 + 24,95) = 0,50$$

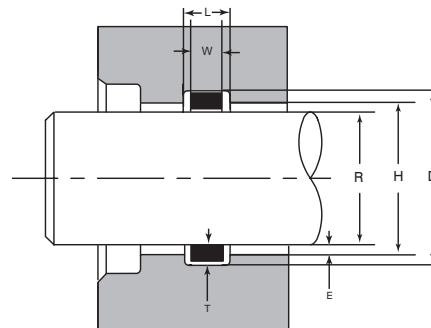

## Important Notice

We reserve the right to make changes without notice in our products and in the information and content of this brochure. The statements and the information in the brochure are intended to serve only as guides. They are not warranties or binding descriptions of the products.

Requests for more information are welcome. In particular, we will be glad to furnish samples for you to inspect and test in your assemblies and plant before you make a final decision on your application.

## Notice of Exclusive Warranty and Remedy

Briefly, our exclusive warranty is against defects in materials and workmanship at the time of shipment. It is in lieu of *all* other warranties. *There is no implied warranty of merchantability or fitness for a particular purpose.* The exclusive remedy is a replacement of defective products or, at our option, a refund of their purchase price. *All damages exceeding the purchase price are excluded,* whether consequential or otherwise and regardless of cause. The terms and conditions on our printed quotation contain a much more complete statement of our Exclusive Warranty and Remedy.



**MACROTECH POLYSEAL, INC.**

**Macrotech Polyseal, Inc.**

1754 West 500 South  
Salt Lake City, Utah 84104  
U.S.A.

(801) 973-9171

Fax (801) 973-9188

*www.polyseal.com*