

Bonded Washers



Elastomer Materials	Temp. Range
Nitrile	-40°C to 120°C
Viton™/Fluorocarbon	-26°C to 204°C
Hydrogenated Nitrile	-40°C to 160°C

Temperature ranges are limited by the elastomers performance range. Other materials are available upon request.

Bonded Washers

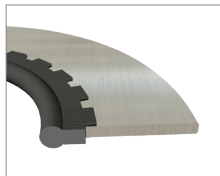

Fastener Seal
600 Series (ST)

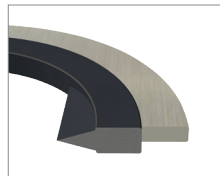

Thread Seal
750 Series (TS)



Bonded Seal
400 Series (BS)

Product Description

Bonded washers are a modified standard washer. They consist of an outer ring of a hard material, typically steel, and an inner ring of an elastomeric material that acts as a gasket. The bonded washers moulded elastomer lining helps prevent fluids from leaking through bolt holes. Outer rings are also available in brass.

Part Numbers:

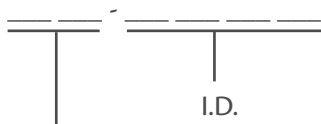

- ST - Fastener Seal
- TS - Threaded Seal
- BS - Bonded Seal

Example: ST 1000 - Fastener Seal, Intended for a 1.000" Thread Diameter, 0.988" Seal I.D., 1.760" O.D.

Bonded Washers

IMPERIAL SEALS

Fastener Seal - 600 Series

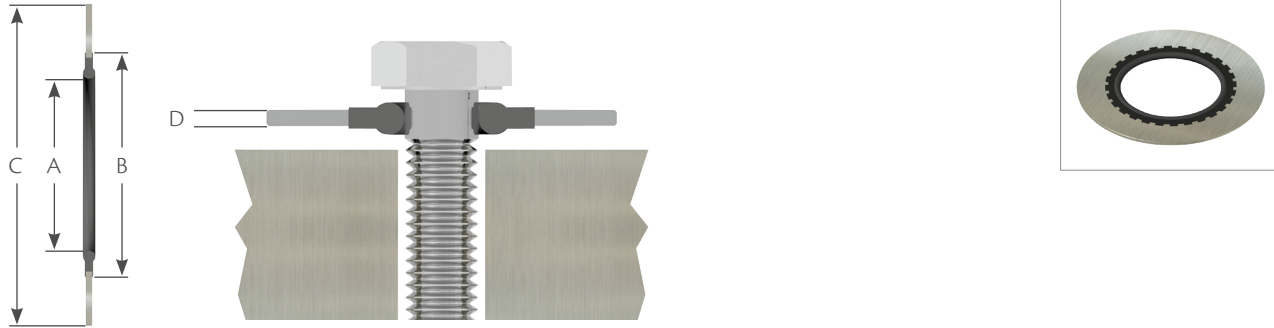

Part Number	Fastener Size	Thread Diameter	A I.D. ± 0.010	B Diameter Max.	C O.D. ± 0.010	D Retainer Thickness
ST 138	#6	0.138	0.130	0.229	0.385	0.040 ± 0.004
ST 164	#8	0.164	0.156	0.255	0.385	0.040 ± 0.004
ST 190	#10	0.190	0.180	0.317	0.443	0.050 ± 0.005
ST 190OS	#10 OS	0.190	0.186	0.365	0.468	0.050 ± 0.005
ST 250	1/4	0.250	0.240	0.381	0.505	0.050 ± 0.005
ST 250OS	1/4 OS	0.250	0.245	0.422	0.531	0.050 ± 0.005
ST 312	5/16	0.312	0.301	0.488	0.603	0.050 ± 0.005
ST 375	3/8	0.375	0.364	0.546	0.666	0.050 ± 0.005
ST 437	7/16	0.438	0.427	0.618	0.760	0.050 ± 0.005
ST 500	1/2	0.500	0.490	0.696	0.880	0.050 ± 0.005
ST 562	9/16	0.562	0.552	0.759	1.067	0.050 ± 0.005
ST 625	5/8	0.625	0.615	0.818	1.193	0.050 ± 0.005
ST 688	11/16	0.688	0.674	0.898	1.260	0.050 ± 0.005
ST 750	3/4	0.750	0.740	0.982	1.322	0.064 ± 0.005
ST 812	13/16	0.812	0.798	1.048	1.416	0.064 ± 0.005
ST 875	7/8	0.875	0.864	1.105	1.510	0.064 ± 0.005
ST 938	15/16	0.938	0.921	1.172	1.635	0.064 ± 0.005
ST 1000	1	1.000	0.988	1.234	1.760	0.064 ± 0.005
ST 1062	1 - 1/16	1.063	1.050	1.290	1.822	0.064 ± 0.005
ST 1125	1 - 1/8	1.125	1.106	1.351	1.885	0.064 ± 0.005
ST 1188	1 - 3/16	1.188	1.167	1.442	1.947	0.064 ± 0.005
ST 1250	1 - 1/4	1.250	1.229	1.474	2.010	0.064 ± 0.005
ST 1312	1 - 5/16	1.313	1.290	1.567	2.072	0.064 ± 0.005
ST 1375	1 - 3/8	1.375	1.352	1.631	2.135	0.064 ± 0.005
ST 1438	1 - 7/16	1.438	1.413	1.693	2.197	0.064 ± 0.005
ST 1500	1 - 1/2	1.500	1.475	1.817	2.260	0.091 ± 0.005
ST 1625	1 - 5/8	1.625	1.600	1.942	2.385	0.091 ± 0.005
ST 1750	1 - 3/4	1.750	1.725	2.067	2.510	0.091 ± 0.005
ST 1875	1 - 7/8	1.875	1.850	2.192	2.635	0.091 ± 0.005
ST 2000	2	2.000	1.975	2.317	2.760	0.091 ± 0.005
ST 3000	3	3.000	2.975	3.430	5.500	0.120 ± 0.005

Bonded Washers

Thread Seal - 750 Series

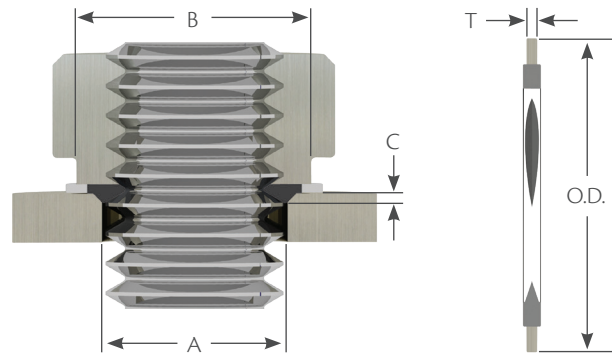
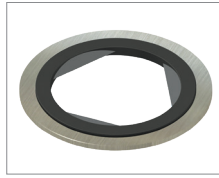

Bonded Washers

Part Number	UNC (Coarse)	UNF (Fine)	O.D. ± 0.010	T Retainer Thickness ± 0.005	A Clearance Diameter	B Min. Dia. of Mating Surface	C Bore Depth
TS 006	32	40	0.406	0.050	0.143/0.149	3/8	3/64
TS 008	32	36	0.406	0.050	0.170/0.177	3/8	3/64
TS 010	24	32	0.469	0.050	0.198/0.206	3/8	1/16
TS 012	24	28	0.562	0.050	0.224/0.234	7/16	1/16
TS 250	20	28	0.562	0.050	0.260/0.271	7/16	1/16
TS 312	18	24	0.687	0.064	0.327/0.339	1/2	1/16
TS 375	16	24	0.750	0.064	0.392/0.406	5/8	1/16
TS 437	14	20	0.906	0.078	0.458/0.474	11/16	1/16
TS 500	13	20	1.000	0.078	0.523/0.541	3/4	1/16
TS 562	12	18	1.094	0.094	0.589/0.609	7/8	1/16
TS 625	11	18	1.187	0.094	0.654/0.676	1	1/16
TS 750	10	16	1.375	0.109	0.788/0.812	1 - 1/8	3/32
TS 875	9	14	1.562	0.109	0.921/0.947	1 - 1/4	3/32
TS 1000	8	12	1.750	0.120	1.054/1.082	1 - 7/16	3/32
TS 1125	8*	12	1.875	0.120	1.187/1.217	1 - 9/16	3/16
TS 1250	8*	12	2.000	0.120	1.321/1.353	1 - 11/16	3/16
TS 1375	8*	12	2.125	0.120	1.454/1.488	1 - 13/16	3/16
TS 1500	8*	12	2.250	0.120	1.587/1.623	1 - 15/16	3/16
TS 1750	5	N/A	3.375	0.179	1.865/1.920	2 - 7/16	3/8

Size 1 - 1/8 to 1 - 1/2 are not designed for standard coarse threads.

Bonded Washers

IMPERIAL SEALS

Bonded Seals - 400 Series

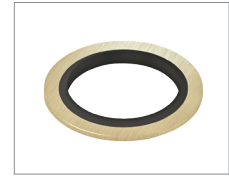
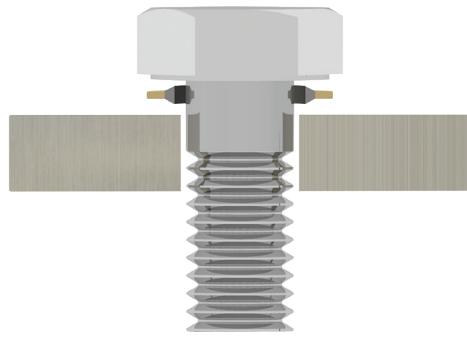

Part Number	Bolt Size	A O.D. + 0.005 - 0.000	B I.D. ±0.004	C Metal Thickness	D Total Height
BS 250	1/4	0.520	0.270	0.051	0.074
BS 312	5/16	0.560	0.340	0.051	0.074
BS 375	3/8	0.625	0.408	0.083	0.113
BS 437	7/16	0.750	0.460	0.083	0.113
BS 500	1/2	0.810	0.541	0.083	0.113
BS 562	9/16	0.875	0.585	0.083	0.113
BS 625	5/8	1.000	0.650	0.083	0.113
BS 687	11/16	1.000	0.715	0.097	0.127
BS 750	3/4	1.060	0.775	0.097	0.127
BS 812	13/16	1.125	0.848	0.097	0.127
BS 875	7/8	1.250	0.925	0.097	0.127
BS 1000	1	1.375	1.065	0.097	0.127
BS 1062	1 - 1/16	1.520	1.095	0.097	0.127
BS 1187	1 - 3/16	1.500	1.213	0.097	0.127
BS 1312	1 - 5/16	1.685	1.334	0.133	0.163
BS 1375	1 - 3/8	1.750	1.415	0.133	0.163
BS 1500	1 - 1/2	1.880	1.534	0.133	0.163
BS 1625	1 - 5/8	2.062	1.690	0.133	0.163
BS 1750	1 - 3/4	2.250	1.905	0.133	0.163
BS 1875	1 - 7/8	2.307	1.907	0.133	0.163
BS 2125	2 - 1/8	2.750	2.161	0.133	0.163
BS 2250	2 - 1/4	2.770	2.285	0.133	0.163

Additional sizes and torque information available through a Hi-Tech Seals representative.