

# Stepped Piston Dimensions

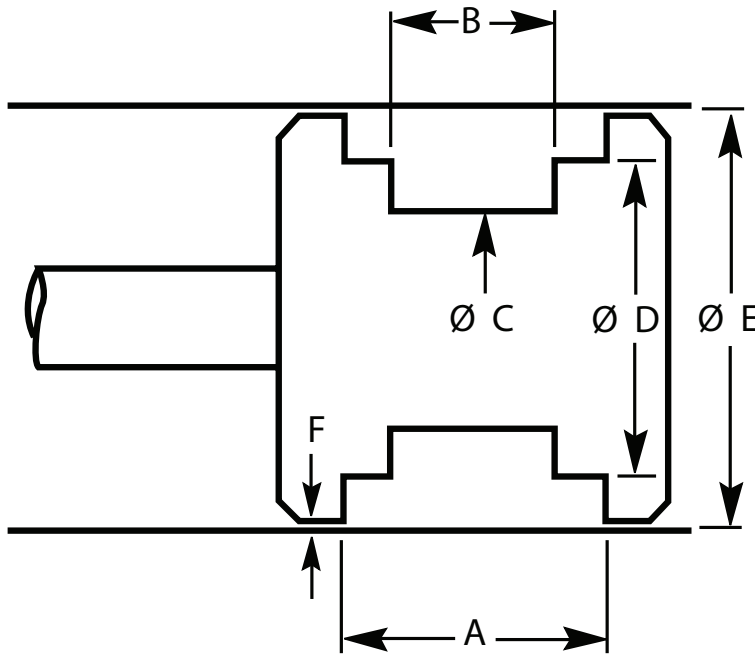

A (Groove Width): \_\_\_\_\_  
 B (Groove Width): \_\_\_\_\_  
 C (Piston Groove Diameter): \_\_\_\_\_  
 D (Groove Diameter): \_\_\_\_\_  
 E (Bore Diameter): \_\_\_\_\_  
 F (Max. Radial Extrusion gap): \_\_\_\_\_

Application Pressure (PSI): \_\_\_\_\_ Application Temperature (°C): \_\_\_\_\_

Are metal/groove modifications permitted (yes/no)? \_\_\_\_\_

Name: \_\_\_\_\_  
 Company: \_\_\_\_\_  
 Phone #: ( ) \_\_\_\_\_  
 Quantity Required: \_\_\_\_\_  
 Attention: \_\_\_\_\_

**For Internal Use:**  
 Hi-Tech Seals Part #: \_\_\_\_\_  
 Hi-Tech Seals Ref#: \_\_\_\_\_

\*It is beneficial to fill out a Seal Application Data Sheet (SADS) along with this form.

**EDMONTON, AB**  
 9211- 41 Avenue NW  
 Ph: (780)-438-6055  
 Fax: (780)-434-5866

**CALGARY, AB**  
 Bay #3, 5940- 30 Street SE  
 Ph: (403)-720-2856  
 Fax: (403)-279-2662

**NEWMARKET, ON**  
 1180 Kerrisdale Blvd; Unit #8  
 Ph: (905)-953-9666  
 Fax: (905)-953-8739

**BOUCHERVILLE, QC**  
 1450 Rue Nobel, Suite #20  
 Tél:(450)-655-7325  
 Téléc: (450)-655-7359