

Seal Ring Materials	Temp. Range
15% Glass Reinforced PTFE	-260°C to 260°C
40% Bronze Reinforced PTFE	-260°C to 260°C
15% Glass, 5% Moly Reinforced PTFE	-260°C to 260°C
25% Carbon Graphite Reinforced PTFE	-260°C to 260°C
40% Glass Reinforced Nylon	-240°C to 149°C
Loader Materials	
Nitrile (NBR)	-40°C to 120°C
Viton™/Fluorocarbon (FKM)	-26°C to 204°C

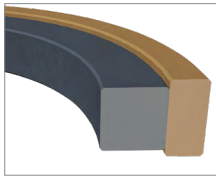

Rectangular (RPS)

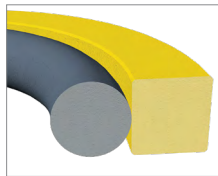

Square (SPS)

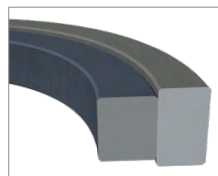

CAT* 2 Piece

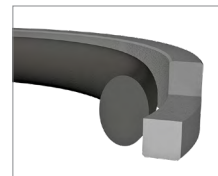

Step Cut (SCP)

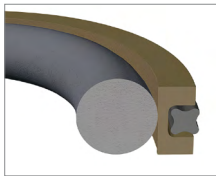

AQ Seal

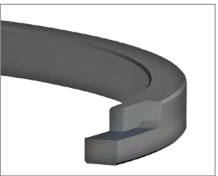

Cast Iron (CI)

*Caterpillar equivalent style

Product Description

Piston rings are excellent for sealing in hydraulic and pneumatic cylinder applications. The piston ring provides excellent low friction and a strong chemical resistance. By changing the piston seals material, the temperature range, frictional characteristics, extrusion resistance, and wearability can be altered.

Part Numbers:

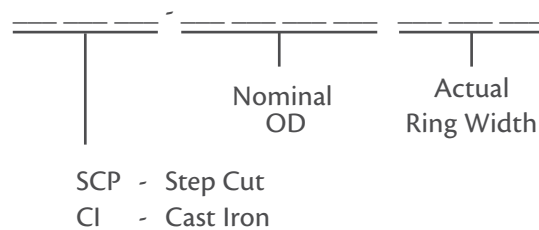
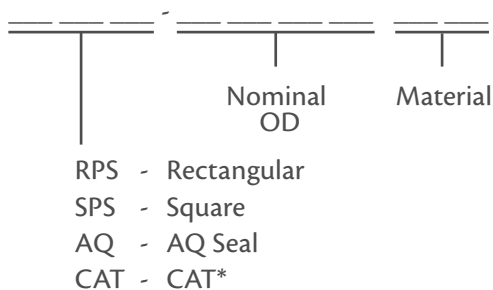

Example: SPS 4000 - 4.000" OD, Square Piston Seal, Glass Reinforced PTFE, 153 NBR O-Ring Loader

Rectangular

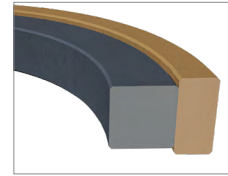
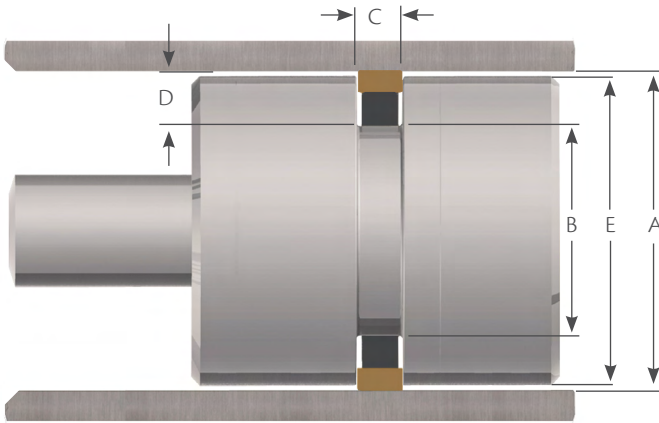

Our standard RPS style rings are composed of a 40% bronze reinforced PTFE ring with a 70A NBR square loader. RPS style rings are used in medium/heavy duty and pneumatic applications. Suitable for pressures up to 5,800 psi.

Range	A Bore Diameter Tol.	D Groove Depth	B Groove Diameter		C Groove Width		E Piston Diameter		Square Ring Series
	Calculation	Tol.	Width	Tol.	Calculation	Tol.			
1.000 - 2.750	+0.002/-0.000	0.155	Dia. A - 0.310	+0.001/-0.001	0.129	+0.002/-0.002	Dia. A - 0.001	+0.000/-0.001	100
3.000 - 5.000	+0.003/-0.000	0.280	Dia. A - 0.560	+0.002/-0.002	0.284	+0.003/-0.003	Dia. A - 0.002	+0.000/-0.002	300
5.250 - 8.500	+0.004/-0.000	0.381	Dia. A - 0.762	+0.003/-0.003	0.379	+0.004/-0.004	Dia. A - 0.003	+0.000/-0.003	400
9.000 - 14.000	+0.004/-0.000	0.439	Dia. A - 0.878	+0.004/-0.004	0.379	+0.004/-0.004	Dia. A - 0.004	+0.000/-0.004	400

Square

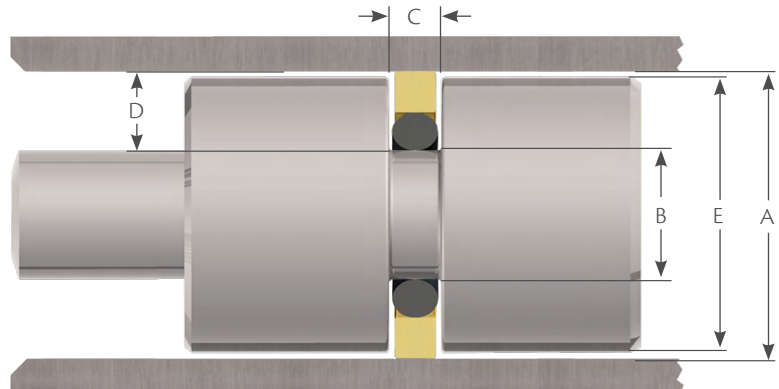
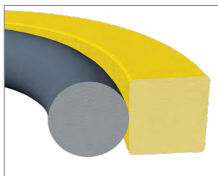

Our standard SPS style rings are composed of a 15% glass reinforced PTFE ring with a 70A NBR loader. SPS style rings are used in light/medium duty and pneumatic applications. Suitable for pressures up to 5,800 psi.

Range	A Bore Diameter Tol.	D Groove Depth	B Groove Diameter		C Groove Width		E Piston Diameter		O-Ring Series
	Calculation	Tol.	Width	Tol.	Calculation	Tol.			
0.500 - 1.500	+0.002/-0.000	0.130	Dia. A - 0.260	+0.001/-0.001	0.083	+0.001/-0.001	Dia. A - 0.001	+0.000/-0.002	0
1.625 - 1.875	+0.002/-0.000	0.196	Dia. A - 0.392	+0.002/-0.002	0.122	+0.002/-0.002	Dia. A - 0.001	+0.000/-0.002	100
2.000 - 5.500	+0.003/-0.000	0.196	Dia. A - 0.392	+0.002/-0.002	0.130	+0.002/-0.002	Dia. A - 0.001	+0.000/-0.003	100
5.750 - 16.000	+0.003/-0.000	0.259	Dia. A - 0.518	+0.003/-0.003	0.160	+0.003/-0.003	Dia. A - 0.002	+0.000/-0.003	200

Loader information is available in the O-ring section, starting on page 1.

CAT

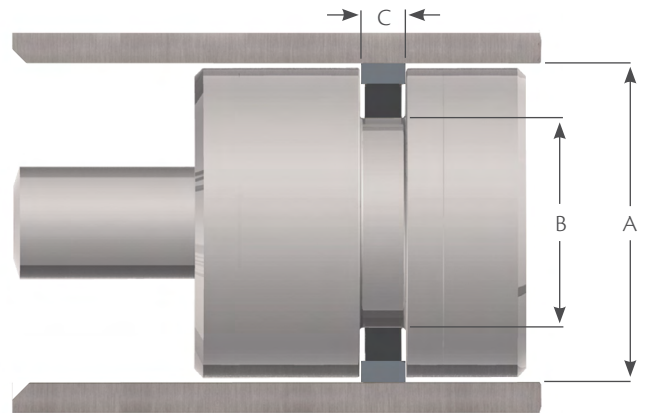
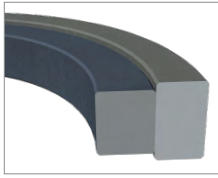

Piston Rings

Part Number	CAT Part Number	A Bore Diameter	B Groove Diameter	C Groove Width
CAT 2000	5J7004	2.000	1.625	0.192
CAT 2500	8J6213	2.500	2.125	0.192
CAT 2750	5J7010	2.750	2.375	0.192
CAT 3000	6J1972	3.000	2.460	0.192
CAT 3250	6J0793	3.250	2.710	0.192
CAT 3500	5J7013	3.500	2.960	0.192
CAT 3750	5J8011	3.750	3.210	0.192
CAT 4000	5J5402	4.000	3.335	0.255
CAT 4250	5J7854	4.250	3.585	0.255
CAT 4500	5J4986	4.500	3.835	0.255
CAT 4750	5J4987	4.750	4.085	0.255
CAT 5000	5J5020	5.000	4.225	0.380
CAT 5250	5J7234	5.250	4.475	0.380
CAT 5500	5J4988	5.500	4.725	0.380
CAT 6000	5J4989	6.000	5.095	0.380
CAT 6250	5J4990	6.250	5.345	0.380
CAT 6500	5J4991	6.500	5.595	0.380
CAT 7000	5J4997	7.000	6.095	0.380
CAT 7250	5J4993	7.250	6.345	0.380
CAT 7500	9J7117	7.500	6.595	0.380
CAT 7750	5J7016	7.750	6.845	0.380
CAT 8250	5J5559	8.250	7.255	0.380
CAT 8500	6J9385	8.500	7.505	0.380

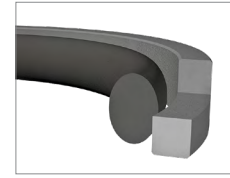
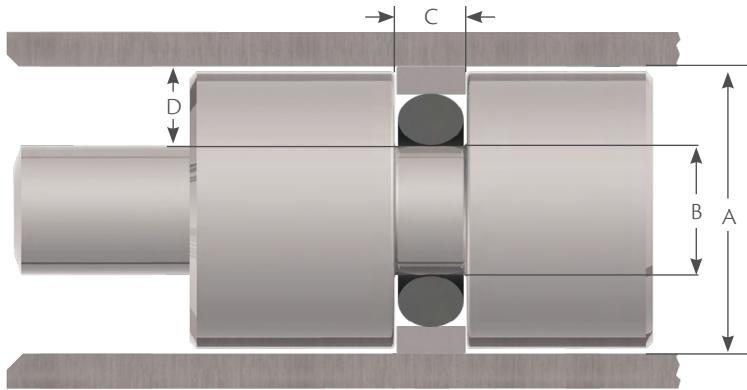

Our standard SCP is composed of a 40% glass reinforced nylon ring and a 90A peroxide cured NBR oval ring.

SCP style piston rings are suitable for pressures up to 10,000 psi. Additionally, they are easier to install due to their split profile.

Part Number	A Bore Dia.	B Groove Dia.	C Groove Width +0.002 -0.000	D Groove Depth
Tolerance	+0.002 -0.000	+0.000 -0.002		
SCP 2000282	2	1.462	0.282	0.269
SCP 2250282	2 - 1/4	1.712	0.282	0.269
Tolerance	+0.003 -0.000	+0.000 -0.002		
SCP 2500282	2 - 1/2	1.962	0.282	0.269
SCP 2500312	2 - 1/2	1.908	0.312	0.296
SCP 2750282	2 - 3/4	2.212	0.282	0.269
SCP 3000312	3	2.408	0.312	0.296
Tolerance	+0.003 -0.000	+0.000 -0.003		
SCP 3000282	3	2.442	0.282	0.279
SCP 3250282	3 - 1/4	2.692	0.282	0.279
SCP 3500282	3 - 1/2	2.942	0.282	0.279
SCP 3500312	3 - 1/2	2.908	0.312	0.296
SCP 3750282	3 - 3/4	3.192	0.282	0.279
SCP 4000282	4	3.442	0.282	0.279
SCP 4000312	4	3.408	0.312	0.296
SCP 4250282	4 - 1/4	3.692	0.282	0.279
SCP 4500282	4 - 1/2	3.942	0.282	0.279
SCP 4500312	4 - 1/2	3.908	0.312	0.296
SCP 4500375	4 - 1/2	3.740	0.377	0.380

Part Number	A Bore Dia.	B Groove Dia.	C Groove Width +0.002 -0.000	D Groove Depth
Tolerance	+0.003 -0.000	+0.000 -0.004		
SCP 4750282	4 - 3/4	4.192	0.282	0.279
SCP 4750375	4 - 3/4	3.990	0.377	0.380
Tolerance	+0.004 -0.000	+0.000 -0.004		
SCP 5000282	5	4.442	0.282	0.279
SCP 5000375	5	4.240	0.377	0.380
SCP 5250375	5 - 1/4	4.490	0.377	0.380
SCP 5500375	5 - 1/2	4.740	0.377	0.380
SCP 5750375	5 - 3/4	4.990	0.377	0.380
SCP 6000375	6	5.240	0.377	0.380
SCP 6500375	6 - 1/2	5.740	0.377	0.380
SCP 7000375	7	6.240	0.377	0.380
SCP 7500375	7 - 1/2	6.740	0.377	0.380
SCP 8000375	8	7.240	0.377	0.380
SCP 8500375	8 - 1/2	7.740	0.377	0.380
SCP 9000375	9	8.124	0.377	0.438
SCP 9500375	9 - 1/2	8.624	0.377	0.438
SCP 10000375	10	9.124	0.377	0.438
SCP 12000375	12	11.124	0.377	0.438

AQ Seals

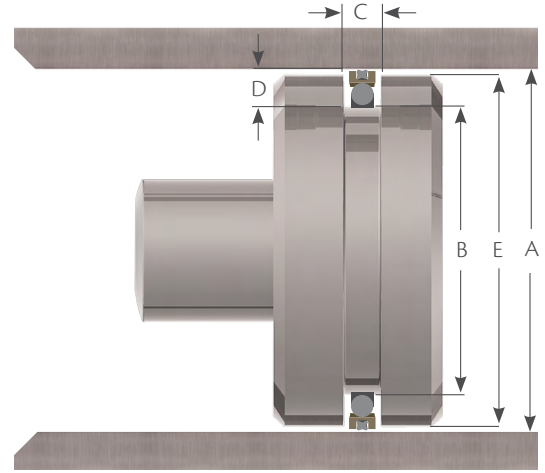
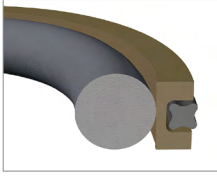

Our Standard AQ seals are composed of a 40% bronze reinforced PTFE ring, an internal O-ring, and an external quad ring.

AQ seals are suitable for pressures up to 5,075 psi. They are commonly used in piston accumulators and medium duty hydraulic cylinders.

A Bore Diameter		D Groove Depth	B Groove Diameter		C Groove Width	E Piston Diameter		Loader Series	Quad- Ring Series
Range	Tol.		Calculation	Tol.		Calculation	Tol.		
1.000 - 2.249	+0.002/-0.000	0.212	Dia. A - 0.424	+0.000/-0.002	0.210	Dia. A - 0.001	+0.000/-0.002	200	100
2.250 - 5.499	+0.002/-0.000	0.308	Dia. A - 0.616	+0.000/-0.002	0.288	Dia. A - 0.001	+0.000/-0.002	300	100
5.500 - 10.000	+0.004/-0.000	0.420	Dia. A - 0.840	+0.000/-0.004	0.375	Dia. A - 0.002	+0.000/-0.004	400	100

Cast Iron

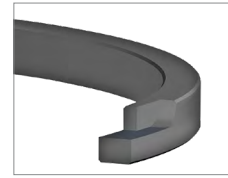
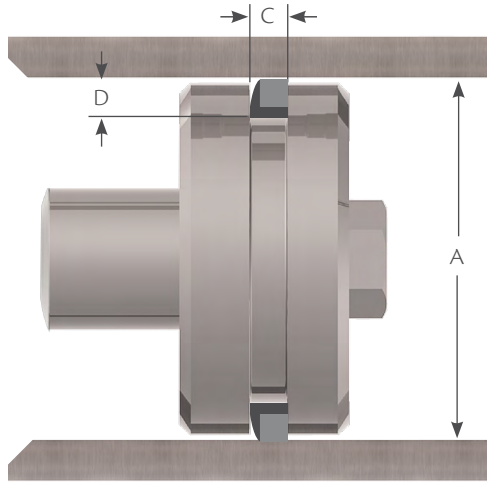

Our Cast Iron style is a metal split ring seal with no expander. They are suitable for hydraulic applications with pressures up to 10,000 psi and temperatures reaching 260°C. The interlock joint allows the seal to pass open ports without clipping the joint tip, effectively minimizing leakage and providing reliable bi-directional sealing.

Part Number	Nominal Width	A Bore Diameter	C Groove Width +0.005/-0.000	D Groove Depth ±.003	Ring Width +0.000/-0.0015	Ring C/S +0.000/-0.015
CI 1500	0.125	1.500	0.1255	0.107	0.124	0.067
CI 1625	0.125	1.625	0.1255	0.116	0.124	0.071
CI 1750	0.125	1.750	0.1255	0.120	0.124	0.075
CI 1875	0.125	1.875	0.1255	0.125	0.124	0.075
CI 2000	0.125	2.000	0.1255	0.125	0.124	0.075
CI 2000187	0.125	2.000	0.1255	0.125	0.187	0.075
CI 2125	0.1875	2.125	0.1880	0.130	0.1865	0.080
CI 2125125	0.1875	2.125	0.1880	0.130	0.125	0.080
CI 2250	0.1875	2.250	0.1880	0.135	0.1865	0.085
CI 2250125	0.1875	2.250	0.1880	0.135	0.125	0.085
CI 2250250	0.1875	2.250	0.1880	0.135	0.250	0.085
CI 2375	0.1875	2.375	0.1880	0.141	0.1865	0.091
CI 2375187	0.1875	2.375	0.1880	0.141	0.187	0.091
CI 2500	0.1875	2.500	0.1880	0.147	0.1865	0.097
CI 2500125	0.1875	2.500	0.1880	0.147	0.125	0.097
CI 2625	0.1875	2.625	0.1880	0.152	0.1865	0.102
CI 2750	0.1875	2.750	0.1880	0.156	0.1865	0.106
CI 2750125	0.1875	2.750	0.1880	0.156	0.125	0.106
CI 2875	0.1875	2.875	0.1880	0.158	0.1865	0.108
CI 3000	0.1875	3.000	0.1880	0.160	0.1865	0.110
CI 3000125	0.1875	3.000	0.1880	0.160	0.125	0.110
CI 3000250	0.1875	3.000	0.1880	0.160	0.250	0.110
CI 3000312	0.1875	3.000	0.1880	0.160	0.312	0.110

Cast Iron

Part Number	Nominal Width	A Bore Diameter	C	D	Ring Width	Ring C/S
			Groove Width +0.005/-0.000	Groove Depth ±.003		
CI 3125	0.1875	3.125	0.1880	0.165	0.1865	0.115
CI 3250	0.1875	3.250	0.1880	0.168	0.1865	0.118
CI 3250125	0.1875	3.250	0.1880	0.168	0.125	0.118
CI 3250155	0.1875	3.250	0.1880	0.168	0.155	0.118
CI 3250250	0.1875	3.250	0.1880	0.168	0.250	0.118
CI 3375	0.1875	3.375	0.1880	0.171	0.1865	0.121
CI 3500	0.1875	3.500	0.1880	0.176	0.1865	0.124
CI 3625	0.1875	3.625	0.1880	0.179	0.1865	0.127
CI 3750	0.250	3.750	0.2505	0.185	0.249	0.130
CI 3750187	0.250	3.750	0.2505	0.185	0.187	0.130
CI 3875	0.250	3.875	0.2505	0.193	0.249	0.138
CI 4000	0.250	4.000	0.2505	0.194	0.249	0.142
CI 4000187	0.250	4.000	0.2505	0.194	0.187	0.142
CI 4000312	0.250	4.000	0.2505	0.194	0.312	0.142
CI 4250	0.250	4.250	0.2505	0.203	0.249	0.150
CI 4250187	0.250	4.250	0.2505	0.203	0.187	0.150
CI 4500	0.250	4.500	0.2505	0.213	0.249	0.160
CI 4500187	0.250	4.500	0.2505	0.213	0.187	0.160
CI 4500312	0.250	4.500	0.2505	0.213	0.312	0.160
CI 4750	0.250	4.750	0.2505	0.221	0.249	0.167
CI 4750187	0.250	4.750	0.2505	0.221	0.187	0.167
CI 4750312	0.250	4.750	0.2505	0.221	0.312	0.167
CI 5000	0.250	5.000	0.2505	0.230	0.249	0.175
CI 5000187	0.250	5.000	0.2505	0.230	0.187	0.175
CI 5000312	0.250	5.000	0.2505	0.230	0.312	0.175
CI 5250	0.250	5.250	0.2505	0.234	0.249	0.181
CI 5250187	0.250	5.250	0.2505	0.234	0.187	0.181
CI 5500	0.250	5.500	0.2505	0.240	0.249	0.190
CI 5500187	0.250	5.500	0.2505	0.240	0.187	0.190
CI 5500312	0.250	5.500	0.2505	0.240	0.312	0.190
CI 5500375	0.250	5.500	0.2505	0.240	0.375	0.190
CI 5750	0.250	5.750	0.2505	0.249	0.249	0.199
CI 5750250	0.250	5.750	0.2505	0.249	0.250	0.199
CI 6000	0.3125	6.000	0.3130	0.256	0.312	0.206
CI 6000250	0.3125	6.000	0.3130	0.256	0.250	0.206
CI 6250	0.3125	6.250	0.3130	0.258	0.312	0.217
CI 6250250	0.3125	6.250	0.3130	0.258	0.250	0.217
CI 6500	0.3125	6.500	0.3130	0.276	0.312	0.226
CI 6500250	0.3125	6.500	0.3130	0.276	0.250	0.226
CI 6500375	0.3125	6.500	0.3130	0.276	0.375	0.226
CI 6750	0.3125	6.750	0.3130	0.284	0.312	0.234
CI 6750250	0.3125	6.750	0.3130	0.284	0.250	0.234
CI 6750375	0.3125	6.750	0.3130	0.284	0.375	0.234
CI 7000	0.3125	7.000	0.3130	0.293	0.312	0.243

Part Number	Nominal Width	A Bore Diameter	C Groove Width	D Groove Depth	Ring Width	Ring C/S
			+0.005/-0.000	±.003		
CI 7000375	0.3125	7.000	0.3130	0.293	0.375	0.243
CI 7000500	0.3125	7.000	0.3130	0.293	0.500	0.243
CI 7250	0.3125	7.250	0.3130	0.302	0.312	0.252
CI 7250250	0.3125	7.250	0.3130	0.302	0.250	0.252
CI 7500	0.3125	7.500	0.3130	0.309	0.312	0.259
CI 7500250	0.3125	7.500	0.3130	0.309	0.250	0.259
CI 7750	0.3125	7.750	0.3130	0.317	0.312	0.267
CI 8000	0.375	8.000	0.3755	0.325	0.374	0.270
CI 8000250	0.375	8.000	0.3755	0.325	0.250	0.270
CI 8000312	0.375	8.000	0.3755	0.325	0.312	0.270
CI 8250	0.375	8.250	0.3755	0.333	0.374	0.283
CI 8500	0.375	8.500	0.3755	0.340	0.374	0.290
CI 8500250	0.375	8.500	0.3755	0.340	0.250	0.290
CI 8500312	0.375	8.500	0.3755	0.340	0.312	0.290
CI 8750	0.375	8.750	0.3755	0.349	0.374	0.299
CI 9000	0.375	9.000	0.3755	0.359	0.374	0.309
CI 9250	0.375	9.250	0.3755	0.365	0.374	0.315
CI 9500	0.375	9.500	0.3755	0.370	0.374	0.320
CI 9500312	0.375	9.500	0.3755	0.370	0.312	0.320
Tolerance					+0.000/-0.002	+0.000/-0.015
CI 10000	0.375	10.000	0.3755	0.382	0.374	0.332
CI 10000312	0.375	10.000	0.3755	0.382	0.312	0.332
CI 10000500	0.375	10.000	0.3755	0.382	0.500	0.332
CI 10500	0.375	10.500	0.3755	0.405	0.374	0.341
CI 11000	0.375	11.000	0.3755	0.420	0.374	0.358
CI 11000370	0.375	11.000	0.3755	0.420	0.370	0.358
CI 11000375	0.375	11.000	0.3755	0.420	0.375	0.358
CI 11000380	0.375	11.000	0.3755	0.420	0.380	0.358
Tolerance					+0.000/-0.002	+0.000/-0.030
CI 11500	0.375	11.500	0.3755	0.436	0.374	0.373
CI 12000	0.375	12.000	0.3755	0.446	0.374	0.401
CI 12000375	0.375	12.000	0.3755	0.446	0.375	0.401
CI 12000422	0.375	12.000	0.3755	0.446	0.422	0.401
CI 12500	0.5	12.500	0.5005	0.457	0.499	0.419
CI 12500500	0.5	12.500	0.5005	0.457	0.500	0.419
CI 13000	0.5	13.000	0.5005	0.470	0.499	0.430
CI 13500	0.5	13.500	0.5005	0.480	0.499	0.440
CI 14000	0.5	14.000	0.5005	0.500	0.499	0.460
CI 14500	0.5	14.500	0.5005	0.520	0.499	0.480
CI 15000	0.5	15.000	0.5005	0.537	0.499	0.493
CI 15500	0.5	15.500	0.5005	0.545	0.499	0.500
CI 16000	0.5	16.000	0.5005	0.560	0.499	0.517
CI 16000375	0.5	16.000	0.5005	0.560	0.375	0.517
CI 16000620	0.5	16.000	0.5005	0.560	0.620	0.517

Cast Iron

Part Number	Nominal Width	A Bore Diameter	C	D	Ring Width	Ring C/S
			Groove Width +0.005/-0.000	Groove Depth ±.003		
CI 16500	0.625	16.500	0.6255	0.580	0.624	0.535
CI 16500500	0.625	16.500	0.6255	0.580	0.500	0.535
CI 17000	0.625	17.000	0.6255	0.592	0.624	0.547
CI 17500	0.625	17.500	0.6255	0.610	0.624	0.555
CI 18000	0.625	18.000	0.6255	0.625	0.624	0.565
CI 18000370	0.625	18.000	0.6255	0.625	0.370	0.565
CI 18500	0.625	18.500	0.6255	0.640	0.624	0.575
CI 19000	0.625	19.000	0.6255	0.655	0.624	0.602
CI 19500	0.625	19.500	0.6255	0.670	0.624	0.610
CI 20000	0.75	20.000	0.7505	0.682	0.7490	0.626
CI 20500	0.75	20.500	0.7505	0.690	0.7490	0.637
CI 21000	0.75	21.000	0.7505	0.705	0.7490	0.642
CI 21500	0.75	21.500	0.7505	0.715	0.7490	0.647
CI 22000	0.75	22.000	0.7505	0.722	0.7490	0.652
CI 22000750	0.75	22.000	0.7505	0.722	0.750	0.652
CI 22500	0.75	22.500	0.7505	0.730	0.7490	0.655
CI 22500940	0.75	22.500	0.7505	0.730	0.940	0.655
CI 23000	0.75	23.000	0.7505	0.745	0.7490	0.680
CI 23500	0.75	23.500	0.7505	0.760	0.7490	0.685
CI 24000	0.75	24.000	0.7505	0.770	0.7490	0.695
CI 24500	0.75	24.500	0.7505	0.780	0.7490	0.704
CI 25000	0.75	25.000	0.7505	0.790	0.7490	0.714
CI 25500	0.75	25.500	0.7505	0.797	0.7490	0.724
CI 26000	0.75	26.000	0.7505	0.815	0.7490	0.730
CI 26500	0.75	26.500	0.7505	0.834	0.7490	0.755
CI 27000	0.75	27.000	0.7505	0.845	0.7490	0.789
CI 27000750	0.75	27.000	0.7505	0.845	0.750	0.789
CI 27500	0.75	27.500	0.7505	0.853	0.7490	0.790
CI 28000	0.75	28.000	0.7505	0.878	0.7490	0.812
CI 28500	0.75	28.500	0.7505	0.902	0.7490	0.835
CI 29000	0.75	29.000	0.7505	0.917	0.7490	0.841
CI 29500	0.75	29.500	0.7505	0.933	0.7490	0.847
CI 30000	0.75	30.000	0.7505	0.940	0.7490	0.852
CI 30500	0.75	30.500	0.7505	0.948	0.7490	0.858
CI 31000	0.75	31.000	0.7505	0.960	0.7490	0.869
CI 31500	0.75	31.500	0.7505	0.974	0.7490	0.881
CI 32000	1	32.000	1.0005	0.987	0.999	0.892